

UHF FM TRANSCEIVER
TK-3300
 SERVICE MANUAL

KENWOOD

Kenwood Corporation

© 2009-8 PRINTED IN JAPAN
 B51-8875-00 (N) 536

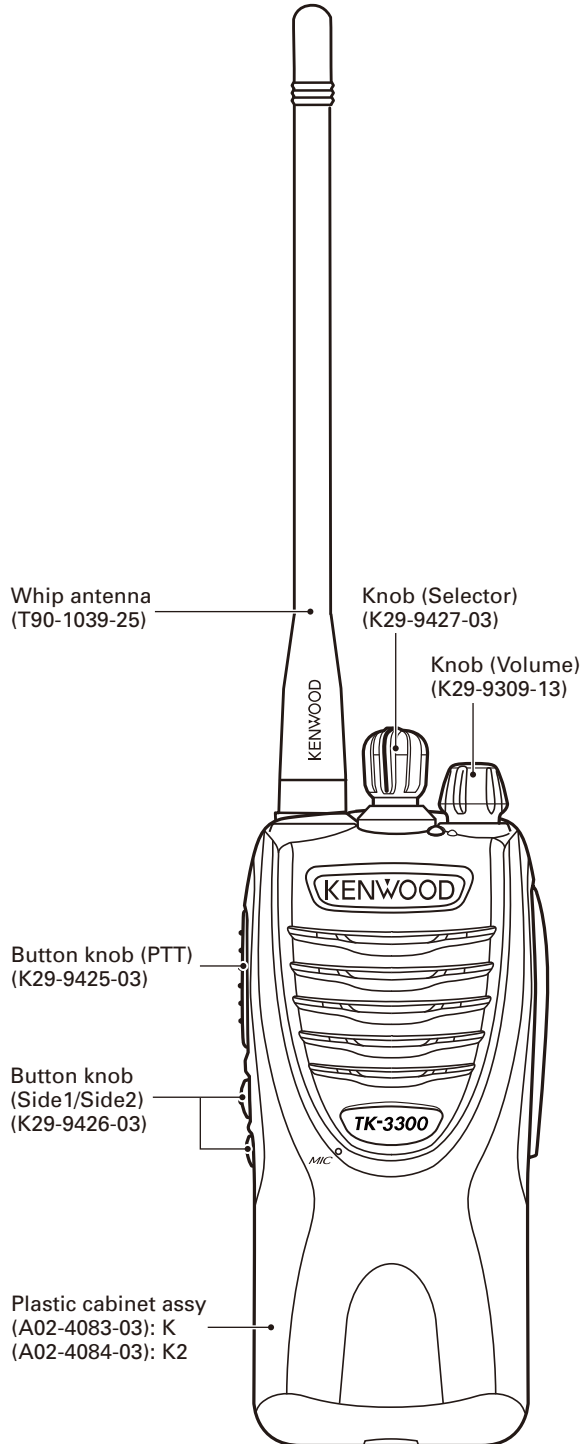

CONTENTS

GENERAL.....2

REALIGNMENT3

DISASSEMBLY FOR REPAIR6

CIRCUIT DESCRIPTION9

SEMICONDUCTOR DATA.....13

TERMINAL FUNCTION13

COMPONENTS DESCRIPTION.....14

PARTS LIST15

EXPLODED VIEW21

PACKING.....22

ADJUSTMENT23

PC BOARD

TX-RX UNIT (X57-7580-11).....28

SCHEMATIC DIAGRAM32

BLOCK DIAGRAM36

LEVEL DIAGRAM38

SPECIFICATIONS39



TK-3300

Document Copyrights

Copyright 2009 by Kenwood Corporation. All rights reserved.

No part of this manual may be reproduced, translated, distributed, or transmitted in any form or by any means, electronic, mechanical, photocopying, recording, or otherwise, for any purpose without the prior written permission of Kenwood.

Disclaimer

While every precaution has been taken in the preparation of this manual, Kenwood assumes no responsibility for errors or omissions. Neither is any liability assumed for damages resulting from the use of the information contained herein. Kenwood reserves the right to make changes to any products herein at any time for improvement purposes.

GENERAL

INTRODUCTION

SCOPE OF THIS MANUAL

This manual is intended for use by experienced technicians familiar with similar types of commercial grade communications equipment. It contains all required service information for the equipment and is current as of the publication date. Changes which may occur after publication are covered by either Service Bulletins or Manual Revisions. These are issued as required.

ORDERING REPLACEMENT PARTS

When ordering replacement parts or equipment information, the full part identification number should be included. This applies to all parts : components, kits, or chassis. If the part number is not known, include the chassis or kit number of which it is a part, and a sufficient description of the required component for proper identification.

PERSONAL SAFETY

The following precautions are recommended for personal safety:

- DO NOT transmit until all RF connectors are verified secure and any open connectors are properly terminated.
- SHUT OFF and DO NOT operate this equipment near electrical blasting caps or in an explosive atmosphere.
- This equipment should be serviced by a qualified technician only.

SERVICE

This transceiver is designed for easy servicing. Refer to the schematic diagrams, printed circuit board views, and alignment procedures contained within.

Model	Type	TX-RX unit	Frequency range	Remarks
TK-3300	K	X57-7580-11	450~470MHz	IF1: 38.85MHz LOC: 38.4MHz
TK-3300	K2			

GENERAL

Destination	Number of CH	Factory default CH setting	RF Power output	Destination	Number of CH	Factory default CH setting	RF Power output
K	1	(02): 464.5500MHz/QT=67.0Hz	2W	K2	7	(13): 461.1375MHz/QT=67.0Hz	2W
	2	(08): 467.9250MHz/QT=67.0Hz			8	(14): 461.1625MHz/QT=67.0Hz	
	3	(09): 461.0375MHz/QT=67.0Hz			9	(01): 464.5000MHz/QT=67.0Hz	
	4	(10): 461.0625MHz/QT=67.0Hz			10	(03): 467.7625MHz/QT=67.0Hz	
K2	1	(02): 464.5500MHz/QT=67.0Hz			11	(04): 467.8125MHz/QT=67.0Hz	
	2	(08): 467.9250MHz/QT=67.0Hz			12	(05): 467.8500MHz/QT=67.0Hz	
	3	(09): 461.0375MHz/QT=67.0Hz			13	(06): 467.8750MHz/QT=67.0Hz	
	4	(10): 461.0625MHz/QT=67.0Hz			14	(07): 467.9000MHz/QT=67.0Hz	
	5	(11): 461.0875MHz/QT=67.0Hz			15	(15): 461.1875MHz/QT=67.0Hz	
	6	(12): 461.1125MHz/QT=67.0Hz			16	(16): 461.2125MHz/QT=67.0Hz	

REALIGNMENT

1. Modes

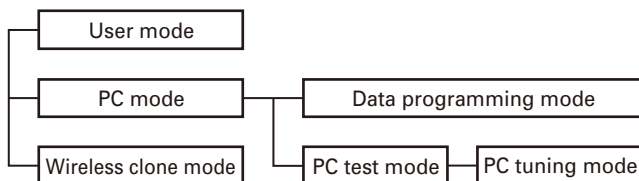

Mode	Function
User mode	For normal use.
PC mode	Used for communication between the transceiver and PC.
Data programming mode	Used to read and write frequency data and other features to and from the transceiver.
PC test mode	Used to check the transceiver using the PC. This feature is included in the FPU.
Wireless clone mode	Used to transfer programming data from one transceiver to another.

2. How to Enter Each Mode

Mode	Operation
User mode	Power ON
PC mode	Received commands from PC
Wireless clone mode	[PTT]+[Side2]+Power ON (Two seconds)

3. PC Mode

3-1. Preface

The transceiver is programmed by using a personal computer, a programming interface (KPG-22/22A, USB adapter (KCT-53U)) and FPU (programming software).

The programming software can be used with a PC. Figure 1 shows the setup of a PC for programming.

3-2. Connection Procedure

1. Connect the transceiver to the personal computer with the interface cable and USB adapter (when the interface cable is KPG-22A, the KCT-53U can be used).

REALIGNMENT

Note:

- You must install the KCT-53U driver in the computer to use the USB adapter (KCT-53U).
- When using the USB adapter (KCT-53U) for the first time, plug the KCT-53U into a USB port on the computer with the computer power ON.

- When the POWER is switched on, user mode can be entered immediately. When the PC sends a command, the transceiver enters PC mode.
When data is read from the transceiver, the red LED lights.
When data is written to by the transceiver, the green LED lights.

Note:

- The data stored in the personal computer must match Model Name and Model Type when it is written into EEPROM.
- Do not press the [PTT] key during data transmission or reception.

3-3. KPG-22/KPG-22A Description

(PC programming interface cable: Option)

The KPG-22/22A is required to interface the transceiver with the computer. It has a circuit in its D-sub connector (KPG-22: 25-pin, KPG-22A: 9-pin) case that converts the RS-232C logic level to the TTL level.

The KPG-22/22A connects the SP/MIC connector of the transceiver to the RS-232C serial port of the computer.

3-4. KCT-53U Description (USB adapter: Option)

The KCT-53U is a cable which connects the KPG-22A to a USB port on a computer.

When using the KCT-53U, install the supplied CD-ROM (with driver software) in the computer. The KCT-53U driver runs under Windows 2000, XP or Vista 32-bit.

3-5. FPU (Programming Software) Description

The FPU is the programming software for the transceiver supplied on a CD-ROM. The software on this disk allows a user to program the transceiver transceivers via Programming interface cable (KPG-22/22A).

3-6. Programming with PC

If data is transferred to the transceiver from a PC with the FPU, the data for each set can be modified.

Data can be programmed into the EEPROM in RS-232C format via the SP/MIC jack.

In this mode the PTT line operate as TXD and RXD data lines respectively.

List of FPU for transceiver

Model	Type	FPU
TK-3300	K,K2	KPG-120D

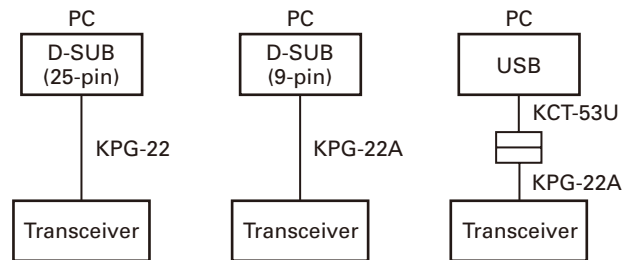
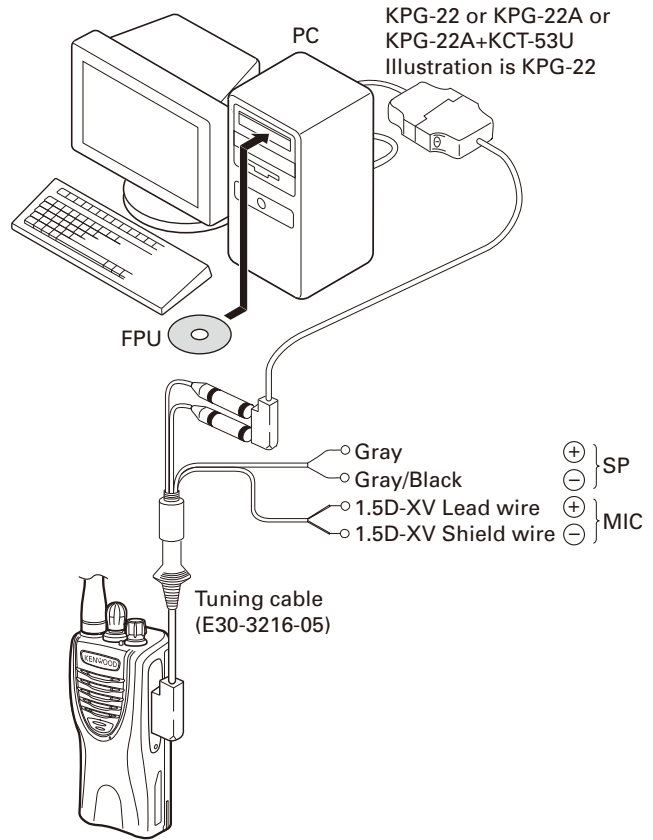

Fig. 1

4. Wireless Clone Mode

4-1. Outline

"Wireless Clone Mode" copies the transceiver data to another transceiver.

The dealer can copy the transceiver data to another transceiver even without the use of a personal computer.

4-2. Example

The transceiver can copy the programming data to one or more transceivers via RF communication.

The clone source and clone target/s must be in wireless clone mode.

REALIGNMENT

4-3. Operation

1. To switch the clone target/s to wireless clone mode, press and hold the [PTT] and [side2] keys while turning the transceiver power ON.
2. Wait for 2 seconds. The LED will light orange and the transceiver will announce "Clone".
3. Select a channel table number using Side1 (increment channel table) and Side2 (decrement channel table) keys.
4. To switch the clone source to wireless clone mode, press and hold the [PTT] and [side2] keys while turning the transceiver power ON.
5. Wait for 2 seconds. The LED will light orange and the transceiver will announce "Clone".
6. Select the same channel table number as the clone target/s.
7. Press [PTT] on the clone source to begin data transmission.
When the clone target starts to receive data, the LED will light green.
When the clone source finishes sending data, a "confirmation" tone will sound.
If data transmission fails while cloning, an "error" tone will sound from the target unit.
8. If the cloning fails, no data will be available in the target unit when it is returned to User mode.
9. When the cloning is successful, the target unit's "Scan" and "Key lock" functions will return to their default values (Scan = OFF, Key lock = OFF).

Note:

- The dealer can clone data to two or more transceivers by repeating the above procedures.
- If the transceivers wireless clone mode is configured as "Disabled", the transceiver cannot enter wireless clone mode.
- The table shown below will cover the frequency tables used for wireless cloning.
- Wireless clone mode cannot be entered in battery low state.
- A unit cannot be a "Source Unit" if it is unprogrammed. If [PTT] is pressed, an "error" tone will sound.
- The language used in cloning depends on the "Model type" setting, not the FPU setting.
- Once a unit is set to be the source, it cannot be a target after the data has been transmitted. This protects the data in the source unit.
- Electronic interface may cause a failure in data transfer during wireless clone, such as when waveforms or electromagnetics are being performed at the workbench.
- **Wireless clone mode can be used ONLY by the authorized service personnel.**
- **The wireless clone mode setting must be configured as "Disable" before being delivered to the end-user.**
- **To clone, replace the antenna from both the source transceiver and the target transceiver with a dummy load.**
- **The transmit output power is automatically set to Low in wireless clone mode.**

• Clone frequency table (BRS UHF Frequencies)

No.	Operating frequency 450-470 [MHz]	No.	Operating frequency 450-470 [MHz]
1	464.5000	46	466.3375
2	464.5500	47	466.3625
3	467.7625	48	467.7875
4	467.8125	49	467.8375
5	467.8500	50	467.8625
6	467.8750	51	467.8875
7	467.9000	52	467.9125
8	467.9250	53	469.4875
9	461.0375	54	469.5125
10	461.0625	55	469.5375
11	461.0875	56	469.5625
12	461.1125	57	462.1875
13	461.1375	58	462.4625
14	461.1625	59	462.4875
15	461.1875	60	462.5125
16	461.2125	61	467.1875
17	461.2375	62	467.4625
18	461.2625	63	467.4875
19	461.2875	64	467.5125
20	461.3125	65	451.1875
21	461.3375	66	451.2375
22	461.3625	67	451.2875
23	462.7625	68	451.3375
24	462.7875	69	451.4375
25	462.8125	70	451.5375
26	462.8375	71	451.6375
27	462.8625	72	452.3125
28	462.8875	73	452.5375
29	462.9125	74	452.4125
30	464.4875	75	452.5125
31	464.5125	76	452.7625
32	464.5375	77	452.8625
33	464.5625	78	456.1875
34	466.0375	79	456.2375
35	466.0625	80	456.2875
36	466.0875	81	456.3375
37	466.1125	82	456.4375
38	466.1375	83	456.5375
39	466.1625	84	456.6375
40	466.1875	85	457.3125
41	466.2125	86	457.4125
42	466.2375	87	457.5125
43	466.2625	88	457.7625
44	466.2875	89	457.8625
45	466.3125		

DISASSEMBLY FOR REPAIR

1. Removing the Case Assembly from the Chassis

1. Remove the volume knob ① and channel knob ②.
2. Remove the two screws ③.
3. Lift and remove the chassis from the case assembly ④.
(Use a flat-blade screwdriver to easily lift the chassis.)

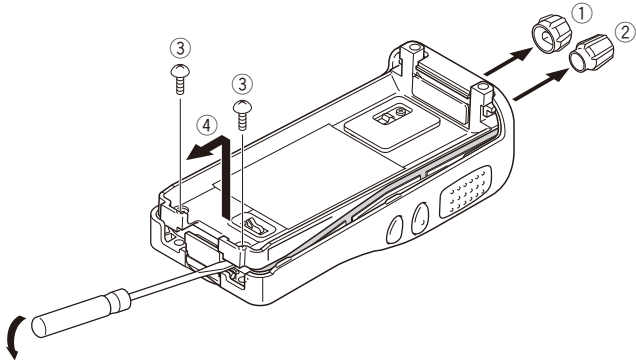

2. Removing the TX-RX unit from the Chassis

1. Detach the solder of speaker wire from the PCB beforehand.
2. Remove the packing ⑤ from the SP/MIC jack of the TX-RX unit.
3. Remove the ten screws ⑥ fixing the TX-RX unit.
4. Remove the solder of the antenna terminal with a soldering iron ⑦.
5. Remove the solder of the positive terminal with a soldering iron ⑧.
- Note:** You can remove the TX-RX unit from the chassis without removing the solder at the positive terminal. However, in this case, you can not attach the packing (G53-1605-03) that is on the positive terminal to the chassis in assembling. So, it is advisable to remove the solder on the positive terminal first.
6. Remove the FPC from the flat cable connector ⑨.
7. Lift and remove the TX-RX unit from the chassis ⑩.

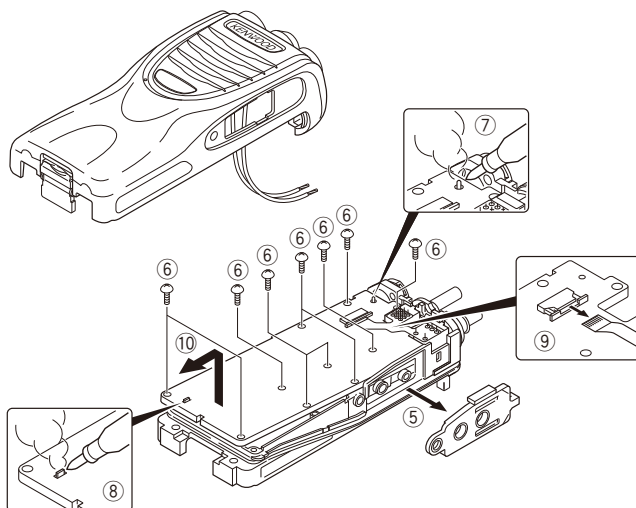

3. Removing the Battery Release Lever from the Case Assembly

1. Press the upper part of the lever toward the inside of the case assembly. One side of the shaft will be removed ①.
2. Lift and remove the battery release lever from the case assembly ②.

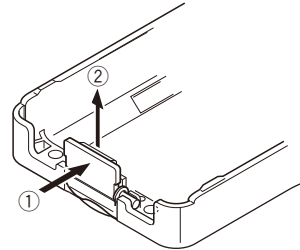

4. Attaching the Battery Release Lever to the Case Assembly

1. Insert one side of the shaft into the hole at the lever fitting section on the case assembly ①.
Caution: The thin spring (G01-4543-04) should be positioned above the two tabs of the lever.
2. Tilt the battery release lever slightly forward ②, so that the thick spring (G01-4542-04) is positioned below the case surface.
3. With the thick spring positioned below the case surface, attach the other side of the shaft to the case assembly by pressing the battery release lever ③ until it snaps into place ④.

Caution: Be careful not to tilt the battery release lever too forward.
If the battery release lever is pushed in this state where the two tabs come below the case surface, there is a possibility of damaging the two tabs.

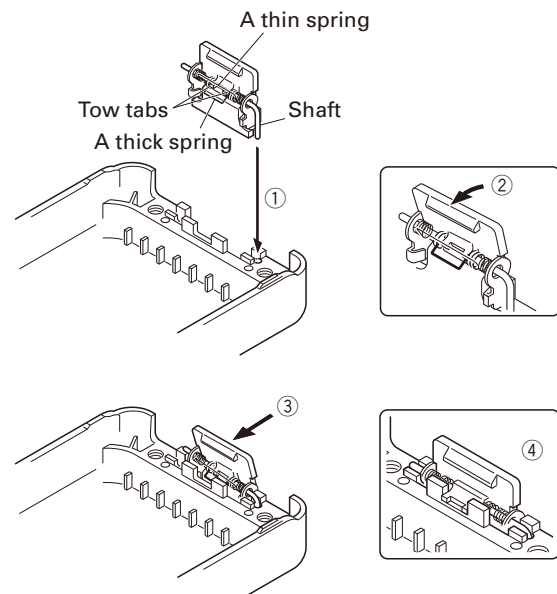

DISASSEMBLY FOR REPAIR

5. Assembling the Battery Release Lever

1. Place the lever ② onto the stopper ①.
2. Place the thick spring ③ onto the lever.
3. Hook the right and left ends of the thin spring ④ onto the tabs of the stopper, then place the thin spring ④ onto the lever ⑤.
4. Slide the shaft through the hole of the stopper and lever ⑥.

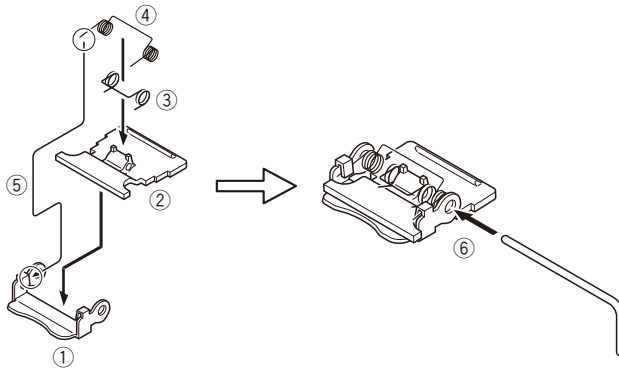

6. Attaching the Positive Terminal to the Chassis

Always attach the positive terminal to the chassis, using the following procedures, before mounting the TX-RX unit onto the chassis.

1. Remove the holder assembly ② from the packing ① of the positive terminal.
2. Mount the packing of the positive terminal into the chassis hole ③.
3. Mount the holder assembly into the packing of the positive terminal ④.

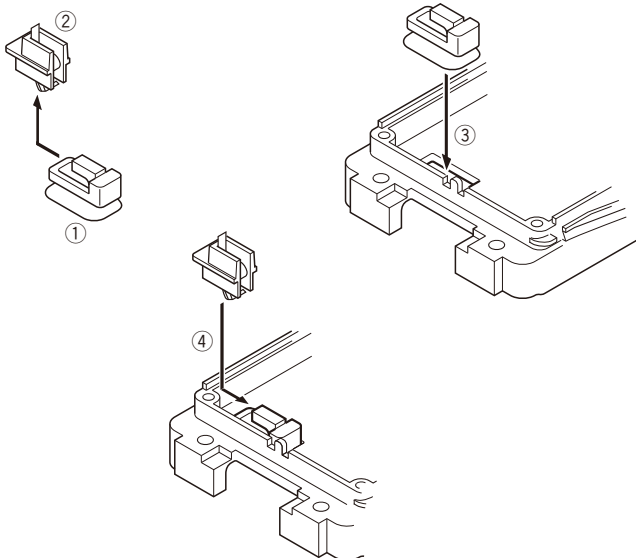

7. Mounting the Chassis to the Case Assembly

1. Confirm that the waterproof packing attached to the circumference of the chassis is securely inserted in the groove of the chassis ①.
2. Attach the speaker with waterproof packing to the speaker recess of the case assembly ②. Make sure the speaker clasp is securely inserted.
3. Tighten the speaker clasp into the case assembly with the screw.
4. Insert the upper part of the chassis into the case assembly ③.
5. Press the chassis ④ and the case assembly together to attach them.

Caution: Take care that the speaker lead wire is not caught by the microphone element.

Caution: If the packing of the SP/MIC does not come to the correct position after attaching the chassis to the case assembly, reposition the packing with your fingers.

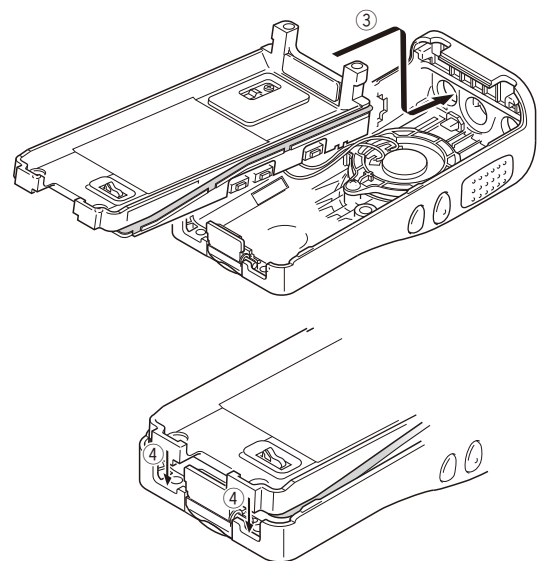
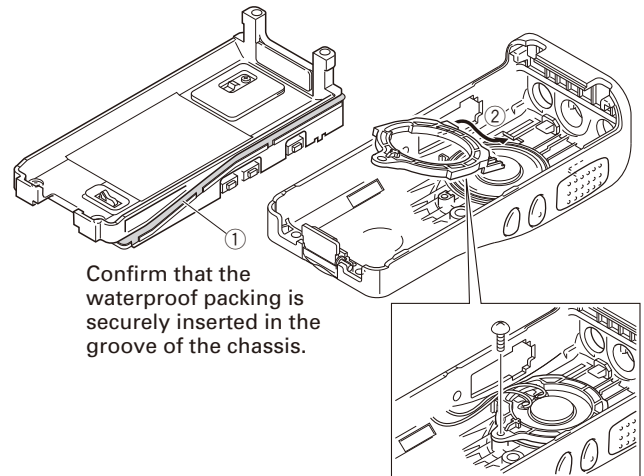

DISASSEMBLY FOR REPAIR

8. Attaching the Antenna Receptacle to the Chassis

Screw the antenna receptacle to the chassis in the order shown in the drawing so that the antenna receptacle comes to the center of the case hole.

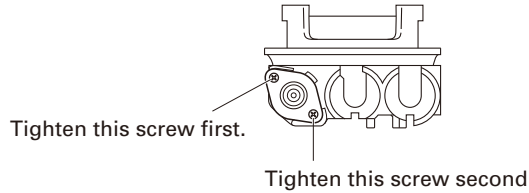

9. The Nuts of the Volume Knob and Channel Knob

Note that the shapes, colors and heights of nuts of the volume knob and channel knob are different from one another. (The nut of volume knob is silver, and the nut of channel knob is gold)

Use the following jig when removing the nuts of the volume knob and channel knob.

- Jig (Part No.: W05-1012-00)

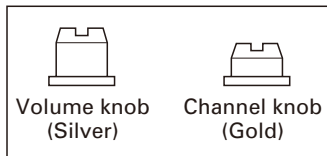

10. Screw sequence for mounting the TX-RX unit to the chassis

Attach the TX-RX unit to the chassis using the screws in the order shown in the drawing below.

Note: From screw ④ onward no sequence is need.

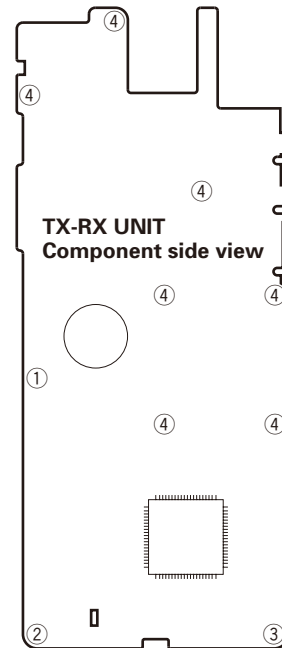

CIRCUIT DESCRIPTION

1. Frequency Configuration

The receiver utilizes double conversion. The first IF is 38.85MHz and the second IF is 450kHz. The first local oscillator signal is supplied from the PLL circuit.

The PLL circuit in the transmitter generates the necessary frequencies. Fig. 1 shows the frequencies.

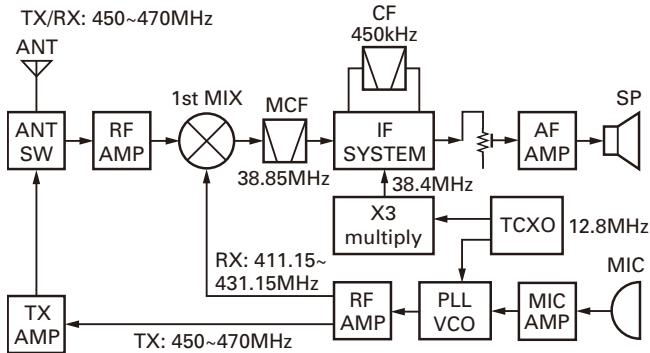

Fig. 1 Frequency configuration

2. Receiver

The frequency configuration of the receiver is shown in Fig. 2.

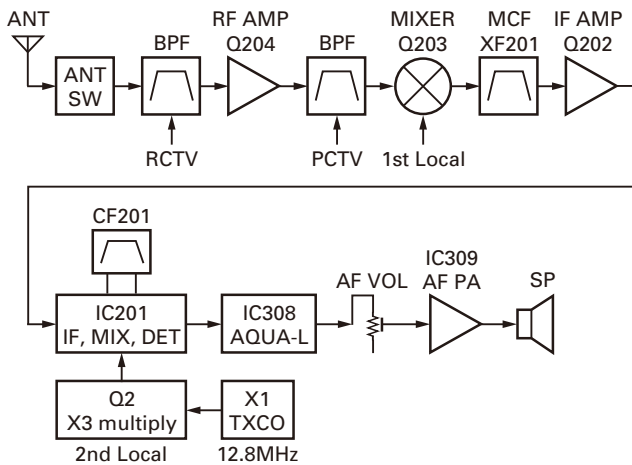

Fig. 2 Receiver section

■ Front End (RF AMP)

The signal coming from the antenna passes through the transmit/receive switching diode circuit, (D103, D104 and D106) passes through a BPF (L213 and L212), and is amplified by the RF amplifier (Q204).

The resulting signal passes through a BPF (L209, L207 and L206) and goes to the mixer. These BPFs are adjusted by variable capacitors (D201, D202, D203, D204 and D205). The input voltage to the variable capacitor is regulated by voltage output from the MCU (IC306).

■ First Mixer

The signal from the front end is mixed with the first local oscillator signal generated in the PLL circuit by Q203 to produce a first IF frequency of 38.85MHz.

The resulting signal passes through the XF201 MCF to cut the adjacent spurious and provide the optimum characteristics, such as adjacent frequency selectivity.

■ IF Amplifier Circuit

The first IF signal is passed through a four-pole monolithic crystal filter (XF201) to remove the adjacent channel signal. The filtered first IF signal is amplified by the first IF amplifier (Q202) and then applied to the IF system IC (IC201). The IF system IC provides a second mixer, limiting amplifier, quadrature detector and RSSI (Received Signal Strength Indicator). The second mixer mixes the first IF signal with the 38.4MHz of the second local oscillator output (TCXO X1 and Q2) and produces the second IF signal of 450kHz.

The second IF signal is passed through the ceramic filter (CF201) to remove the adjacent channel signal. The filtered second IF signal is amplified by the limiting amplifier and demodulated by the quadrature detector with the ceramic discriminator (CD201). The demodulated signal is routed to the audio circuit.

■ Wide/Narrow Switching Circuit

Narrow and Wide settings can be made for each channel by switching the demodulation level.

The WIDE (low level) and NARROW (high level) data is output from IC306, pin 5. When a WIDE (low level) data is received, Q201 turn on. When a NARROW (high level) data is received, Q201 turn off.

Q201 turns on/off with the Wide/Narrow data and the IC201 detector output level is switched to maintain a constant output level during wide or narrow signals.

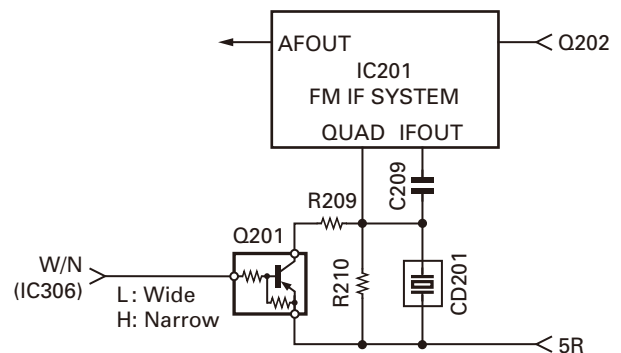

Fig. 3 Wide/Narrow switching circuit

CIRCUIT DESCRIPTION

■ Audio Amplifier Circuit

The demodulated signal from IC201 goes to AF amplifier through IC308.

The signal then goes through an AF volume control, and is routed to an audio power amplifier (IC309) where it is amplified and output to the speaker.

■ Squelch

Part of the AF signal from the IC enters the FM IC (IC201) again, and the noise component is amplified and rectified by a filter and an amplifier to produce a DC voltage corresponding to the noise level.

The DC signal from the FM IC goes to the analog port of the MCU (IC306). IC306 determines whether to output sounds from the speaker by checking whether the input voltage is higher or lower than the preset value.

To output sounds from the speaker, IC306 sends a high signal to the AF_CONT line and turns IC309 on through Q312, Q313, Q314, Q315 and Q316. (See Fig. 4)

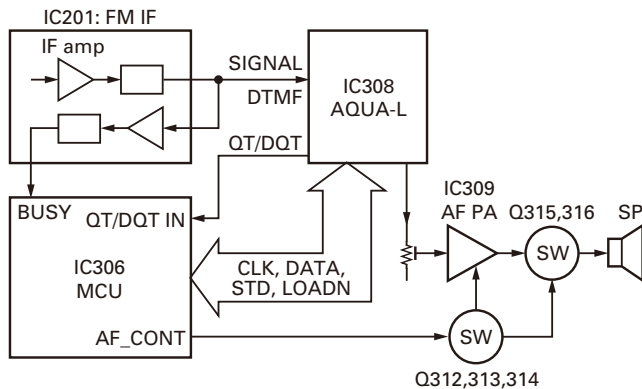

Fig. 4 AF amplifier and squelch

■ Receive Signaling

• QT/DQT

The output signal from FM IC (IC201) enters the MCU (IC306) through IC308. IC306 determines whether the QT or DQT matches the preset value, and controls the SP MUTE and the speaker output sounds according to the squelch results.

• MSK (Fleet Sync)

The MSK input signal from the FM IC goes to pin 31 of IC 308. The signal is demodulated by MSK demodulator in IC 308. The demodulated data goes to the MCU for processing.

• DTMF

The DTMF input signal from the FM IC (IC201) goes to IC308. The decoded information is then processed by the MCU.

3. PLL Frequency Synthesizer

The PLL circuit generates the first local oscillator signal for reception and the RF signal for transmission.

■ PLL

The frequency step of the PLL circuit is 5 or 6.25kHz.

A 12.8MHz reference oscillator signal is divided at IC1 by a fixed counter to produce an oscillator (VCO) output signal which is buffer amplified by Q3 then divided in IC1 by a programmable counter. The divided signal is compared in phase with the 5 or 6.25kHz reference signal from the phase comparator in IC1. The output signal from the phase comparator is filtered through a low-pass filter and passed to the VCO to control the oscillator frequency. (See Fig. 5)

■ VCO

The operating frequency is generated by Q5 in transmit mode and Q4 in receive mode. The oscillator frequency is controlled by applying the VCO control voltage, obtained from the phase comparator, to the varactor diodes (D4 and D8 in transmit mode and D3 and D6 in receive mode).

The RX_SW pin is set high in receive mode causing Q7 turn on. The TX_SW pin is set high in transmit mode. The outputs from Q4 and Q5 are amplified by Q9 and sent to the RF amplifiers.

■ Unlock Detector

If a pulse signal appears at the LD pin of IC1, an unlock condition occurs, and the DC voltage obtained from C4 and Q1 causes the voltage applied to the MCU to go low. When the MCU detects this condition, the transmitter is disabled, ignoring the push-to-talk switch input signal.

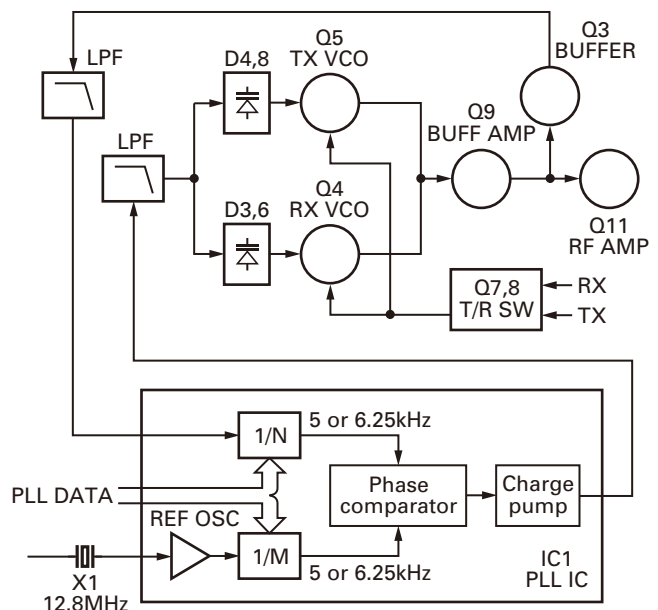

Fig. 5 PLL circuit

CIRCUIT DESCRIPTION

4. Transmitter System

■ Microphone Amplifier

The signal from the microphone passes through the IC308. When encoding DTMF, it is turned OFF for muting the microphone input signal by IC308.

The signal passes through the Audio processor (IC308) for the maximum deviation adjustment, and goes to the VCO modulation input.

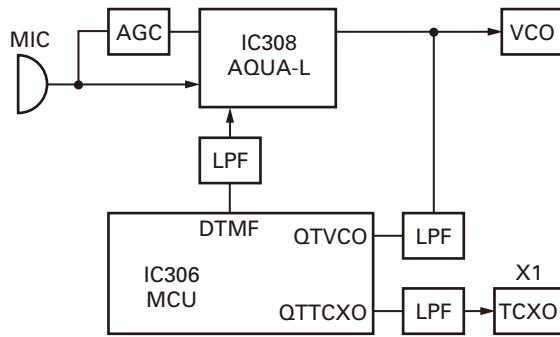

Fig. 6 Microphone amplifier

■ Drive and Final Amplifier

The signal from the T/R switch (D10 is on) is amplified by the pre-drive (Q101 and Q102) and the drive amplifier (Q103) to 500mW.

The output of the drive amplifier is amplified by the RF power amplifier (Q106) to 2.0W (1W when the power is low). The output of the RF power amplifier is then passed through the harmonic filter (LPF) and antenna switch (D103) and applied to the antenna terminal.

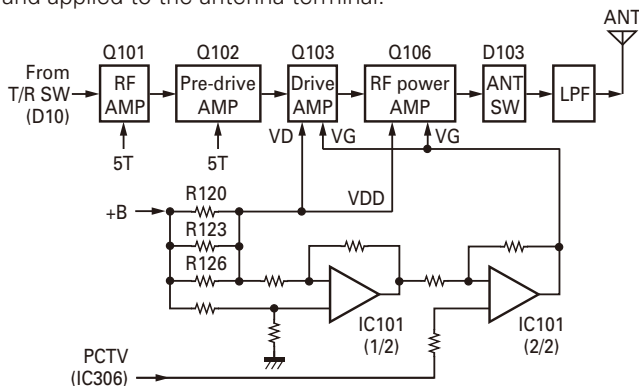

Fig. 7 Drive and final amplifier and APC circuit

■ APC Circuit

The APC circuit always monitors the current flowing through the drive amplifier and RF power amplifier (Q103 and Q106) and keeps a constant current.

The voltage drop at R120, R123 and R126 is caused by the current flowing through the RF power amplifier and drive amplifier, and this voltage is applied to the differential amplifier IC101 (1/2).

IC101 (2/2) compares the output voltage of IC101 (1/2) with the reference voltage from IC306. The output of IC101 (2/2) controls the VG of the RF power amplifier and drive amplifier to make both voltages the same.

The change of power high/low is carried out by the change of the reference voltage.

■ Encode Signaling

• QT/DQT

QT/DQT data of the QTTCXO Line is output from pin 14 of the MCU. The signal passes through a low-pass CR filter and goes to the TCXO (X1).

The QT/DQT data of the QTVCO Line is output from pin 15 of the MCU. The signal passes through a low pass CR filter, mixes with the audio signal, and goes to the VCO modulation input. TX deviation is adjusted by the MCU.

• DTMF

High-speed data is output from pin 74 of the MCU. The signal passes through a low-pass CR filter, and provides a TX and SP out tone, and is then applied to the audio processor (IC308). The signal is mixed with the audio signal and goes to the VCO.

TX deviation is adjusted by the MCU.

• MSK (Fleet Sync)

Fleet Sync utilizes 1200bps and 2400bps MSK signal is output from pin 6 of IC308. And is routed to the VCO. When encoding MSK, the microphone input signal is muted.

5. Power Supply

There are four 5V power supplies in the transceiver: 5M, 5C, 5R, and 5T. 5M for MCU is always output while the power is on. 5M is always output, but turns off when the power is turned off to prevent malfunction of the MCU.

5C is a common 5V and is output when SAVE is not set to OFF.

5R is 5V for reception and output during reception.

5T is 5V for transmission and output during transmission.

6. Control Circuit

The control circuit consists of a MCU (IC306) and its peripheral circuits. It controls the TX-RX unit. IC306 mainly performs the following:

- 1) Switching between transmission and reception by the PTT signal input.
- 2) Reading system, group, frequency, and program data from the memory circuit.
- 3) Sending frequency program data to the PLL.
- 4) Controlling squelch on/off by the DC voltage from the squelch circuit.
- 5) Controlling the audio mute circuit by the decode data input.
- 6) Transmitting tone and encode data.

CIRCUIT DESCRIPTION

■ Frequency Shift Circuit

The MCU (IC306) operates at a clock of 14.746 MHz. This oscillator has a circuit that shifts the frequency by BEAT SHIFT SW (Q305, Q306).

A beat sound may be able to be evaded from generation if "Beat Shift" is set to ON when it is generated in the internal spurious transmission modulated sound of a transceiver.

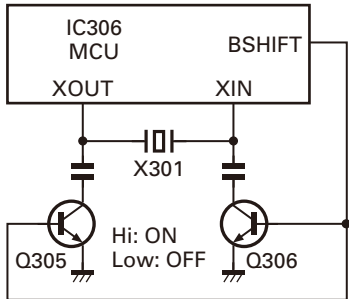

Fig. 8 Frequency shift circuit

■ Memory Circuit

Memory circuit consists of the MCU (IC306) and an EEPROM (IC305). An EEPROM has a capacity of 16k bits that contains the transceiver control program for the MCU and data such as transceiver channels and operating features.



Fig. 9 Memory circuit

■ Low Battery Warning

The battery voltage is checked using by the MCU. The transceiver generates a warning tone when it falls below the warning voltage shown in the table.

1) The red LED blinks when the battery voltage falls below the voltage (1) shown in the table during transmission.

Note: The transceiver checks the battery voltage during reception even when, in the FPU, the Battery Warning status function is set to "On TX" (default setting).

However, the LED does not blink during reception. During transmission, the LED blinks to generate the warning tone of a low battery voltage.

2) The transceiver immediately stops transmission when the battery voltage falls below the voltage (2) shown in the table. A message tone beeps while the PTT switch is released.

	Ni-Cd Battery	Ni-MH Battery	Li-ion Battery
(1)	6.2V	6.2V	6.2V
(2)	5.9V	5.9V	5.9V

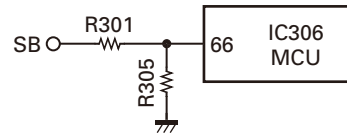

Fig. 10 Low battery warning

7. Control System

Keys and channel selector circuit. The signal from the keys and channel selector are directly input to the MCU, as shown in Fig. 11.

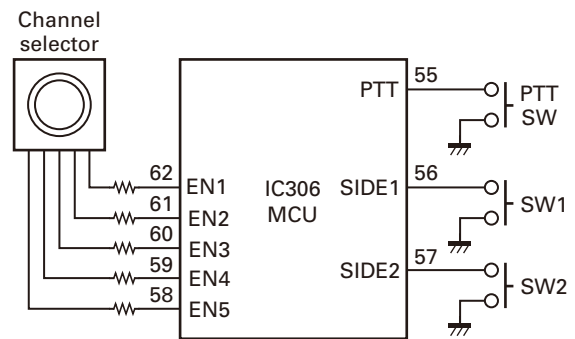

Fig. 11 Control system

SEMICONDUCTOR DATA

MCU: R5F212CCKCME (TX-RX unit IC306)

Pin No.	Signal Name	I/O	Function
1	5T_C	O	5T control
2	PLL_STB	O	PLL strobe
3	5C_C	O	5C control
4	5R_C	O	5R control
5	W/N	O	Wide/Narrow switch
6	MODE	I	No function
7	AF_CONT	O	Speaker mute
8	BSHIFT	O	Beat shift control
9	RESET	I	MCU reset
10	XOUT	O	MCU clock (14.746MHz)
11	VSS	-	GND
12	XIN	I	MCU clock (14.746MHz)
13	VCC	I	Power supply input
14	QTTCXO	O	QT/DQT output
15	QTVCO	O	QT/DQT output
16~21	AUX6~AUX1	I/O	No function
22	MIC_MUTE	O	MIC mute
23	AF_MUTE	O	No function
24~32	N.C	O	No function
33	RXDATA	I	No function
34	TXDATA	O	No function
35	OPTDET	I	Headset detect
36	TX_SW	O	TX VCO switch
37	RX_SW	O	RX VCO switch
38	LEDRX	O	Green LED control
39	LEDTX	O	Red LED control
40	APC_SW	O	APC switch
41	DC_SW	O	APC discharge switch
42	STD	I	Baseband IC data input
43	1/2 OSC	O	Baseband IC clock (3.6864MHz)
44	INT	I	No function
45	TXD	O	Serial data output

Pin No.	Signal Name	I/O	Function
46	RXD	I	Serial data input
47	DIR	O	Baseband IC data output
48	DI/O	I/O	Baseband IC data input / output
49	DTRLOADN	O	Baseband IC data output
50	TDATA/DTRCLK	O	Baseband IC data output
51	SCLK	O	Serial clock for baseband IC
52	TCLK/DTRDO	I	Baseband IC data input
53	RDF/FD	I	Baseband IC data input
54	MDSW	I	No function
55	PTT	I	PTT switch input
56	SIDE1	I	Side1 key input
57	SIDE2	I	Side2 key input
58~62	EN5~EN1	I	Channel selector input
63	DIST1	I	No function
64	DIST2	I	No function
65	PLL_UL	I	PLL unlock signal input
66	BATT	I	Battery voltage detect
67	RSSI	I	RSSI input
68	BUSY	I	Busy signal input
69	VOX	I	VOX signal detect
70	QT/DQT_IN	I	QT/DQT signal input
71	EEPCLK	O	EEPROM clock
72	EEPDAT	I/O	EEPROM data input / output
73	TH_DET	I	Temperature detect
74	DTMF	I	DTMF/BEEP output
75	AVSS	-	GND
76	PCTV	I	APC/BPF control voltage
77	VREF	I	Reference voltage input
78	AVCC	I	Power supply input
79	PLL_DAT	O	PLL data output
80	PLL_CLK	O	PLL clock output

TERMINAL FUNCTION

TX-RX unit (X57-7580-11)

Pin No.	Name	I/O	Function
CN301			
1	B	I	B (Battery Voltage)
2	SB	O	Switched B
3	AFVOL_IN	I	Audio input
4	AFVOL_OUT	O	Audio output
5	AFVOL_GND	-	GND

Pin No.	Name	I/O	Function
6	EN1	I	Encoder pulse input
7	EN2	I	Encoder pulse input
8	GND	-	GND
9	EN3	I	Encoder pulse input
10	EN4	I	Encoder pulse input
11	EN5	I	Encoder pulse input

COMPONENTS DESCRIPTION

TX-RX unit (X57-7580-11)

Ref. No.	Part Name	Description
IC1	IC	PLL system IC
IC101	IC	APC
IC201	IC	FM system IC
IC301	IC	Voltage detector/ Reset
IC303,304	IC	Voltage regulator/ 5V
IC305	IC	EEPROM
IC306	IC	MCU
IC308	IC	Audio processor
IC309	IC	Audio amplifier
Q1	Transistor	Rectification
Q2	Transistor	Tripler
Q3	Transistor	RF amplifier
Q4	FET	VCO/ RX
Q5	FET	VCO/ TX
Q6	Transistor	Rectification
Q7	Transistor	DC switch/ RX VCO
Q8	Transistor	DC switch/ TX VCO
Q9	Transistor	RF amplifier
Q10	Transistor	Ripple filter
Q11	Transistor	RF amplifier
Q101,102	Transistor	RF amplifier
Q103	FET	TX drive amplifier
Q104	Transistor	Discharge switch
Q105	FET	Current control
Q106	FET	TX final amplifier
Q107	Transistor	DC switch
Q108	FET	DC switch
Q109	Transistor	DC switch
Q201	Transistor	Wide/Narrow switch/ RX
Q202	Transistor	IF amplifier
Q203	FET	Mixer
Q204	FET	Low noise amplifier

Ref. No.	Part Name	Description
Q301	Transistor	DC switch/ Red color LED
Q302	Transistor	DC switch/ Green color LED
Q303	Transistor	DC switch/ 5R
Q304	Transistor	DC switch/ 5T
Q305,306	Transistor	Beat shift switch
Q307	Transistor	Wide/Narrow switch/ TX
Q308	Transistor	Rectification
Q310,311	Transistor	MIC mute
Q312,313	Transistor	DC switch
Q314	Transistor	Mute switch
Q315,316	FET	Mute switch
D3	Variable Capacitance Diode	Frequency control/ RX VCO
D4	Variable Capacitance Diode	Frequency control/ TX VCO
D6	Variable Capacitance Diode	Frequency control/ RX VCO
D8	Variable Capacitance Diode	Frequency control/ TX VCO
D9	Variable Capacitance Diode	Modulator
D10	Diode	TX/RX RF switch
D101	Zener diode	Voltage protection
D103,104,106	Diode	ANT switch
D201~205	Variable Capacitance Diode	RF BPF tuning
D301	Diode	Reverse voltage protection
D302	Diode	Rectification
D303	LED	Red color LED
D304	LED	Green color LED
D306	Diode	Rectification
D307	Diode	Limiter
D308,309	Diode	Rectification

PARTS LIST

* New Parts. Δ indicates safety critical components.

Parts without **Parts No.** are not supplied.

Les articles non mentionnés dans le **Parts No.** ne sont pas fournis.

Teile ohne **Parts No.** werden nicht geliefert.

L : Scandinavia

Y : PX (Far East, Hawaii)

Y : AAFES (Europe)

K : USA

T : England

X : Australia

P : Canada

E : Europe

M : Other Areas

TK-3300

TX-RX UNIT (X57-7580-11)

Ref. No.	Address	New parts	Parts No.	Description	Desti-nation
TK-3300					
1	1A	*	A02-4083-03	PLASTIC CABINET	K
1	1A	*	A02-4084-03	PLASTIC CABINET	K2
2	3A	*	A10-4131-03	CHASSIS	
4	2C		B09-0725-03	CAP ACCESSORY	
7	1C	*	B62-2159-00	INSTRUCTION MANUAL	
9	1A		D10-0649-03	LEVER	
10	1A		D21-0863-04	SHAFT	
11	1A		D32-0441-13	STOPPER	
12	1B	*	D32-0448-04	STOPPER	K
13	2B		E04-0477-15	ANTENNA CONNECTOR (SMA)	
14	3A		E23-1253-04	TERMINAL (BATT-)	
15	2A		E23-1254-04	TERMINAL (BATT+)	
16	2B		E37-1175-15	SP WIRE LEAD (BROWN)	
17	2B		E37-1176-15	SP WIRE LEAD (GREEN)	
19	3A		F20-3353-14	INSULATING SHEET (CHASSIS BATT+)	
21	1A		G01-4542-04	COIL SPRING (LEVER)	
22	1A		G01-4543-14	COIL SPRING (STOPPER)	
23	2A		G10-1330-04	FIBROUS SHEET (AUDIO IC)	
24	2A		G11-4465-04	RUBBER SHEET (FINAL FET)	
25	3B		G13-2009-04	CUSHION (CHASSIS)	
26	3A		G13-2033-04	CUSHION (BATT-)	
27	3A		G13-2034-14	CUSHION (CHASSIS-)	
28	3A		G13-2038-24	CUSHION (CHASSIS-CERAMIC FILTER)	
29	2A		G13-2039-14	CUSHION	
30	1A		G13-2285-04	CUSHION	
31	2A	*	G13-2286-04	CUSHION	K
32	3A		G53-1604-03	PACKING (CHASSIS)	
33	2A		G53-1605-03	PACKING (BATT+)	
34	2A		G53-1609-14	PACKING (ECM)	
35	2B		G53-1799-03	PACKING (VOLUME/SELECTOR)	
36	1B		G53-1800-03	PACKING (SP/MIC)	
37	1B		G53-1801-03	PACKING (SPEAKER)	
38	2B		G53-1802-04	PACKING (SMA)	
39	2D		H12-4251-05	PACKING FIXTURE	
42	3D		H52-2300-13	ITEM CARTON CASE	
46	2A		J19-5463-03	HOLDER (BATT+)	
47	2A		J19-5473-03	HOLDER ASSY (BATT+)	
48	2C		J19-5521-03	HOLDER (SP/MIC)	
49	2B		J19-5522-03	HOLDER (SPERKER CLASP)	
50	2C		J29-0734-05	BELT HOOK	
51	2A		J82-0121-05	FPC	K2
51	2A	*	J82-0124-05	FPC	K
52	1A		J99-0737-04	ADHESIVE SHEET	
54	1B		K29-9309-13	KNOB (VOLUME)	
55	1A		K29-9425-03	BUTTON KNOB (PTT)	
56	1A		K29-9426-03	BUTTON KNOB (MON/PF)	
57	1B		K29-9427-03	KNOB (SELECTOR)	
A	3B		N14-0848-05	CIRCULAR NUT (SELECTOR)	
B	3B		N14-0849-05	CIRCULAR NUT (VOLUME)	
C	2B		N30-2604-48	PAN HEAD MACHINE SCREW (SMA)	
D	3A		N30-2606-48	PAN HEAD MACHINE SCREW	

Ref. No.	Address	New parts	Parts No.	Description	Desti-nation
E	2A,3A,2B		N83-2005-48	PAN HEAD TAPTITE SCREW	
61	2C		N99-2046-05	SCREW SET	
63	2A		R31-0670-25	VARIABLE RESISTOR	
65	2A		S60-0435-15	ROTARY SWITCH	K
65	2A		S60-0440-05	ROTARY SWITCH	K2
67	1B		T07-0369-15	SPEAKER	
68	2D		T90-1039-25	WHIP ANTENNA	
71	1D		W08-0988-05	CHARGER	
72	1D	*	W08-0989-25	AC ADAPTER	
73	1C	*	W09-1033-25	BATTERY ASSY	
TX-RX UNIT (X57-7580-11)					
D303			B30-2315-05	LED (RED)	
D304			B30-2314-05	LED (GREEN)	
C1			CK73HB1H332K	CHIP C 3300PF	K
C2			CK73HB1C682K	CHIP C 6800PF	K
C3			CK73GB1A105K	CHIP C 1.0UF	K
C4			CK73HB1A104K	CHIP C 0.10UF	K
C5			CK73HB1H471K	CHIP C 470PF	K
C6			CK73HB1E103K	CHIP C 0.010UF	K
C7			CC73HCH1H100D	CHIP C 10PF	D
C8-10			CC73HCH1H101J	CHIP C 100PF	J
C11			CK73FB0J106K	CHIP C 10UF	K
C12			CK73HB1H471K	CHIP C 470PF	K
C13			CC73HCH1H100D	CHIP C 10PF	D
C14,15			CK73HB1E103K	CHIP C 0.010UF	K
C16			CC73HCH1H470J	CHIP C 47PF	J
C17			CK73HB1E103K	CHIP C 0.010UF	K
C18			CC73HCH1H180J	CHIP C 18PF	J
C21			CK73HB1E103K	CHIP C 0.010UF	K
C22			CK73FB0J106K	CHIP C 10UF	K
C23			CK73HB1E103K	CHIP C 0.010UF	K
C25			CC73HCH1H300J	CHIP C 30PF	J
C26			CC73HCH1H020B	CHIP C 2.0PF	B
C27			CS77CA1VR22M	CHIP TNTL 0.22UF	35WV
C29			CC73HCH1H270J	CHIP C 27PF	J
C30			CK73HB1H471K	CHIP C 470PF	K
C31			CK73HB1E103K	CHIP C 0.010UF	K
C32			CS77CA1C3R3M	CHIP TNTL 3.3UF	16WV
C33			CK73HB1H471K	CHIP C 470PF	K
C35			CS77CA1V0R1M	CHIP TNTL 0.1UF	35WV
C36			CK73HB1H332K	CHIP C 3300PF	K
C37			CS77CA1V0R1M	CHIP TNTL 0.1UF	35WV
C39			CK73HB1C682K	CHIP C 6800PF	K
C40			CC73HCH1H050B	CHIP C 5.0PF	B
C41			CC73HCH1H030B	CHIP C 3.0PF	B
C42			CC73HCH1H050B	CHIP C 5.0PF	B
C44,45			CK73GB1A105K	CHIP C 1.0UF	K
C47			CC73HCH1H100C	CHIP C 10PF	C
C50			CK73HB1H471K	CHIP C 470PF	K
C51			CC73HCH1H100D	CHIP C 10PF	D
C52,53			CC73HCH1H060B	CHIP C 6.0PF	B

PARTS LIST

TX-RX UNIT (X57-7580-11)

Ref. No.	Address	New parts	Parts No.	Description	Destination	Ref. No.	Address	New parts	Parts No.	Description	Destination
C55			CC73HCH1H020B	CHIP C 2.0PF B		C170			CC73GCH1H101J	CHIP C 100PF J	
C56,57			CC73HCH1H060B	CHIP C 6.0PF B		C172			CC73GCH1H050B	CHIP C 5.0PF B	
C58			CC73HCH1H010B	CHIP C 1.0PF B		C173			CC73GCH1H0R5B	CHIP C 0.5PF B	
C59			CC73HCH1H1R5B	CHIP C 1.5PF B		C174			CC73GCH1H060B	CHIP C 6.0PF B	
C60			CC73HCH1H040B	CHIP C 4.0PF B		C175			CC73GCH1H010B	CHIP C 1.0PF B	
C61			CC73HCH1H030B	CHIP C 3.0PF B		C176			CC73GCH1H060B	CHIP C 6.0PF B	
C62			CK73HB1H471K	CHIP C 470PF K		C177			CC73GCH1H2R5B	CHIP C 2.5PF B	
C63			CC73HCH1H060B	CHIP C 6.0PF B		C178			CC73GCH1H040B	CHIP C 4.0PF B	
C64			CC73HCH1H050B	CHIP C 5.0PF B		C201			CK73GB1C224K	CHIP C 0.22UF K	
C65			CC73HCH1H060B	CHIP C 6.0PF B		C202			CK73FB0J106K	CHIP C 10UF K	
C66			CK73HB1H471K	CHIP C 470PF K		C203			CK73HB1E103K	CHIP C 0.010UF K	
C67			CC73HCH1H050B	CHIP C 5.0PF B		C204			CK73HB1H102K	CHIP C 1000PF K	
C68			CK73HB1H471K	CHIP C 470PF K		C205			CK73HB1H182K	CHIP C 1800PF K	
C70			CC73HCH1H0R5B	CHIP C 0.5PF B		C206,207			CK73HB1H681K	CHIP C 680PF K	
C71			CC73HCH1H0R3B	CHIP C 0.3PF B		C208			CK73HB1A104K	CHIP C 0.10UF K	
C72,73			CK73HB1A104K	CHIP C 0.10UF K		C209			CC73HCH1H680J	CHIP C 68PF J	
C74,75			CK73HB1H471K	CHIP C 470PF K		C210-213			CK73HB1A104K	CHIP C 0.10UF K	
C76			CS77CP0J100M	CHIP TNL 10UF 6.3WV		C214			CC73HCH1H020B	CHIP C 2.0PF B	
C77			CK73HB1H471K	CHIP C 470PF K		C215,216			CK73HB1E103K	CHIP C 0.010UF K	
C78			CC73HCH1H330J	CHIP C 33PF J		C219			CC73HCH1H010B	CHIP C 1.0PF B	
C79,80			CK73HB1H471K	CHIP C 470PF K		C220			CC73HCH1H180J	CHIP C 18PF J	
C81			CC73HCH1H150J	CHIP C 15PF J		C222			CK73HB1H471K	CHIP C 470PF K	
C83-85			CK73HB1H471K	CHIP C 470PF K		C223			CK73HB1E103K	CHIP C 0.010UF K	
C86			CC73HCH1H100B	CHIP C 10PF B		C224			CK73HB1A104K	CHIP C 0.10UF K	
C101			CK73HB1H471K	CHIP C 470PF K		C225			CK73HB1E103K	CHIP C 0.010UF K	
C102			CK73GB1H471K	CHIP C 470PF K		C226			CK73HB1H471K	CHIP C 470PF K	
C103			CC73HCH1H300J	CHIP C 30PF J		C227			CC73HCH1H180J	CHIP C 18PF J	
C104			CC73HCH1H040B	CHIP C 4.0PF B		C228			CK73HB1H471K	CHIP C 470PF K	
C106			CK73GB1A105K	CHIP C 1.0UF K		C230			CK73HB1E103K	CHIP C 0.010UF K	
C107			CK73HB1H471K	CHIP C 470PF K		C231			CK73HB1H471K	CHIP C 470PF K	
C108			CK73GB1A105K	CHIP C 1.0UF K		C232			CC73HCH1H3R5B	CHIP C 3.5PF B	
C109			CC73HCH1H060B	CHIP C 6.0PF B		C233			CC73HCH1H060B	CHIP C 6.0PF B	
C111			CK73GB1A105K	CHIP C 1.0UF K		C234			CK73HB1H471K	CHIP C 470PF K	
C112,113			CK73HB1H471K	CHIP C 470PF K		C236			CC73GCH1H4R5B	CHIP C 4.5PF B	
C114			CK73HB1A104K	CHIP C 0.10UF K		C237			CC73HCH1H220J	CHIP C 22PF J	
C115			CC73HCH1H060B	CHIP C 6.0PF B		C238			CC73HCH1H010B	CHIP C 1.0PF B	
C117			CC73HCH1H110J	CHIP C 11PF J		C239			CK73HB1H471K	CHIP C 470PF K	
C120			CK73HB1H471K	CHIP C 470PF K		C240			CC73HCH1H020B	CHIP C 2.0PF B	
C124			CK73HB1H471K	CHIP C 470PF K		C241			CK73FB0J106K	CHIP C 10UF K	
C125			CC73HCH1H100B	CHIP C 10PF B		C242			CC73HCH1H060B	CHIP C 6.0PF B	
C126			CC73HCH1H300J	CHIP C 30PF J		C243			CK73HB1H471K	CHIP C 470PF K	
C127			CC73HCH1H160J	CHIP C 16PF J		C244			CC73HCH1H220J	CHIP C 22PF J	
C128,129			CK73HB1H471K	CHIP C 470PF K		C245			CC73HCH1H010B	CHIP C 1.0PF B	
C130			CK73GB1A105K	CHIP C 1.0UF K		C246			CK73HB1H471K	CHIP C 470PF K	
C131			CK73HB1E103K	CHIP C 0.010UF K		C247			CC73HCH1H020B	CHIP C 2.0PF B	
C133			CK73GB1A105K	CHIP C 1.0UF K		C248			CC73HCH1H220J	CHIP C 22PF J	
C135,136			CK73HB1H471K	CHIP C 470PF K		C249			CC73GCH1H4R5B	CHIP C 4.5PF B	
C137			CC73HCH1H101J	CHIP C 100PF J		C250			CK73HB1H471K	CHIP C 470PF K	
C140			CK73HB1H471K	CHIP C 470PF K		C252-254			CK73HB1H471K	CHIP C 470PF K	
C141			CK73HB1A104K	CHIP C 0.10UF K		C256			CK73HB1H471K	CHIP C 470PF K	
C142			CC73GCH1H430J	CHIP C 43PF J		C257			CC73HCH1H3R5B	CHIP C 3.5PF B	
C144			CK73HB1H471K	CHIP C 470PF K		C258			CC73HCH1H220J	CHIP C 22PF J	
C146			CC73GCH1H120J	CHIP C 12PF J		C259			CC73HCH1H020B	CHIP C 2.0PF B	
C154			CK73HB1H471K	CHIP C 470PF K		C260			CK73HB1H471K	CHIP C 470PF K	
C156			CC73GCH1H080B	CHIP C 8.0PF B		C261			CC73HCH1H2R5B	CHIP C 2.5PF B	
C161			CC73GCH1H040B	CHIP C 4.0PF B		C262			CC73HCH1H220J	CHIP C 22PF J	
C166			CC73GCH1H060B	CHIP C 6.0PF B		C263			CC73HCH1H010B	CHIP C 1.0PF B	
C167			CK73HB1H471K	CHIP C 470PF K		C264,265			CC73HCH1H3R5B	CHIP C 3.5PF B	
C168			CC73GCH1H040B	CHIP C 4.0PF B		C266			CC73HCH1H050B	CHIP C 5.0PF B	
C169			CC73GCH1H2R5B	CHIP C 2.5PF B		C290			CC73HCH1H020B	CHIP C 2.0PF B	

PARTS LIST

TX-RX UNIT (X57-7580-11)

Ref. No.	Address	New parts	Parts No.	Description	Destination	Ref. No.	Address	New parts	Parts No.	Description	Destination
C291			CC73HCH1H060B	CHIP C 6.0PF B		C399			CC73HCH1H101J	CHIP C 100PF J	
C303			CC73HCH1H101J	CHIP C 100PF J		C400			CK73FBOJ106K	CHIP C 10UF K	
C304			CK73HB1A104K	CHIP C 0.10UF K		C402			CK73HB1A104K	CHIP C 0.10UF K	
C305			CC73HCH1H101J	CHIP C 100PF J		C403			CK73HB1A473J	CHIP C 0.047UF J	
C306			CK73GB1A105K	CHIP C 1.0UF K		C404			CS77CC0J101M	CHIP TNL 100UF 6.3VW	
C307			CC73HCH1H101J	CHIP C 100PF J		C405			CC73HCH1H221J	CHIP C 220PF J	
C310			CK73GB1A105K	CHIP C 1.0UF K		C408,409			CK73HB1H471K	CHIP C 470PF K	
C311			CC73HCH1H101J	CHIP C 100PF J		C411			CK73HB1H471K	CHIP C 470PF K	
C312			CK73HB1H471K	CHIP C 470PF K		C413-415			CK73HB1H471K	CHIP C 470PF K	
C313			CC73HCH1H101J	CHIP C 100PF J		TC1,2			C05-0384-05	CERAMIC TRIMMER CAPACITOR (10P)	
C315			CC73HCH1H101J	CHIP C 100PF J		CN301			E40-6573-05	FLAT CABLE CONNECTOR	
C316			CK73HB1H471K	CHIP C 470PF K		J301			E11-0703-05	PHONE JACK (2.5/3.5)	
C318			CK73HB1E103K	CHIP C 0.010UF K		101	2A	*	F12-0493-04	CONDUCTIVE SHEET	
C319			CK73HB1H102K	CHIP C 1000PF K		F301			F53-0324-05	FUSE (2.5A)	
C320			CC73HCH1H101J	CHIP C 100PF J		102	2A		J30-1282-14	SPACER	
C321			CK73GB1A105K	CHIP C 1.0UF K		CD201			L79-1866-05	TUNING COIL	
C322			CC73HCH1H101J	CHIP C 100PF J		CF201	2A		L72-0973-05	CERAMIC FILTER	
C323			CK73GB1A105K	CHIP C 1.0UF K		L1			L92-0138-05	CHIP FERRITE	
C325			CC73HCH1H101J	CHIP C 100PF J		L2			L40-4791-86	SMALL FIXED INDUCTOR (4.7UH)	
C327			CK73HB1H471K	CHIP C 470PF K		L4			L40-5681-86	SMALL FIXED INDUCTOR (0.56UH)	
C331			CK73HB1A104K	CHIP C 0.10UF K		L6			L40-5681-86	SMALL FIXED INDUCTOR (0.56UH)	
C332			CC73HCH1H050B	CHIP C 5.0PF B		L7			L92-0138-05	CHIP FERRITE	
C334			CK73HB1E103K	CHIP C 0.010UF K		L8			L40-1875-71	SMALL FIXED INDUCTOR (18NH)	
C335			CK73FBOJ106K	CHIP C 10UF K		L9			L92-0470-05	CHIP FERRITE	
C337			CC73HCH1H050B	CHIP C 5.0PF B		L10,11			L40-1885-92	SMALL FIXED INDUCTOR (180NH)	
C339			CK73GB1A105K	CHIP C 1.0UF K		L12			L40-1875-71	SMALL FIXED INDUCTOR (18NH)	
C341			CK73HB1H471K	CHIP C 470PF K		L13,14			L40-1885-92	SMALL FIXED INDUCTOR (180NH)	
C353-355			CK73HB1E103K	CHIP C 0.010UF K		L15			L40-2778-67	SMALL FIXED INDUCTOR (27NH)	
C356			CK73HB1H102K	CHIP C 1000PF K		L16			L40-2278-67	SMALL FIXED INDUCTOR (22NH)	
C358			CK73GB1C224K	CHIP C 0.22UF K		L17,18			L41-2785-45	SMALL FIXED INDUCTOR (270NH)	
C359			CK73FBOJ106K	CHIP C 10UF K		L19,20			L40-1885-92	SMALL FIXED INDUCTOR (180NH)	
C360			CK73HB1A104K	CHIP C 0.10UF K		L21			L92-0138-05	CHIP FERRITE	
C361			CK73GB1A105K	CHIP C 1.0UF K		L22,23			L40-2275-71	SMALL FIXED INDUCTOR (22NH)	
C362			CK73HB1H471K	CHIP C 470PF K		L101			L40-1875-71	SMALL FIXED INDUCTOR (18NH)	
C363			CC73HCH1H820J	CHIP C 82PF J		L102			L40-3375-71	SMALL FIXED INDUCTOR (33NH)	
C364			CC73HCH1H120J	CHIP C 12PF J		L103			L40-1575-71	SMALL FIXED INDUCTOR (15NH)	
C365			CC73HCH1H820J	CHIP C 82PF J		L104			L40-1068-71	SMALL FIXED INDUCTOR (1.0NH)	
C366			CK73HB1A104K	CHIP C 0.10UF K		L105			L41-1078-45	SMALL FIXED INDUCTOR (10NH)	
C367			CK73GB1A105K	CHIP C 1.0UF K		L106			L92-0472-05	CHIP FERRITE	
C368			CK73HB1H271K	CHIP C 270PF K		L107			L40-3363-92	SMALL FIXED INDUCTOR (3.3NH)	
C369,370			CK73HB1A104K	CHIP C 0.10UF K		L108			L34-4603-15	AIR-CORE COIL	
C371			CK73FBOJ106K	CHIP C 10UF K		L109			L92-0472-05	CHIP FERRITE	
C372			CK73HB1H471K	CHIP C 470PF K		L111			L41-2785-45	SMALL FIXED INDUCTOR (270NH)	
C373			CC73HCH1H121J	CHIP C 120PF J		L112			L34-4572-05	AIR-CORE COIL	
C374			CK73HB1H102K	CHIP C 1000PF K		L113-115			L34-4564-05	AIR-CORE COIL	
C375,376			CK73HB1H471K	CHIP C 470PF K		L116			L41-1092-44	SMALL FIXED INDUCTOR (1UH)	
C377			CK73HB1A683K	CHIP C 0.068UF K		L201			L40-1091-86	SMALL FIXED INDUCTOR (1.0UH)	
C378			CC73HCH1H820J	CHIP C 82PF J		L202			L92-0138-05	CHIP FERRITE	
C379,380			CK73GB1A105K	CHIP C 1.0UF K		L203			L41-5685-39	SMALL FIXED INDUCTOR (0.56U)	
C381			CK73HB1H391K	CHIP C 390PF K		L204			L40-1885-92	SMALL FIXED INDUCTOR (180NH)	
C382			CK73HB1C153K	CHIP C 0.015UF K		L205			L40-2775-71	SMALL FIXED INDUCTOR (27NH)	
C383-385			CK73HB1A104K	CHIP C 0.10UF K		L206,207			L41-8268-14	SMALL FIXED INDUCTOR (8.2NH)	
C386			CK73HB1E103K	CHIP C 0.010UF K		L208			L92-0138-05	CHIP FERRITE	
C388,389			CK73HB1H471K	CHIP C 470PF K		L209			L41-8268-14	SMALL FIXED INDUCTOR (8.2NH)	
C390,391			CK73GB1A105K	CHIP C 1.0UF K		L210			L41-2785-45	SMALL FIXED INDUCTOR (270NH)	
C392			CK73HB1A473K	CHIP C 0.047UF K		L212,213			L41-8268-14	SMALL FIXED INDUCTOR (8.2NH)	
C393			CK73FBOJ106K	CHIP C 10UF K		L214			L41-4775-45	SMALL FIXED INDUCTOR (47NH)	
C395			CC73HCH1H221J	CHIP C 220PF J		L250			L40-1875-71	SMALL FIXED INDUCTOR (18NH)	
C396			CK73HB1A104K	CHIP C 0.10UF K							
C397			CK73GB1C474K	CHIP C 0.47UF K							

If a part reference number is listed in a shaded box, that part does not come with the PCB.

PARTS LIST

TX-RX UNIT (X57-7580-11)

Ref. No.	Address	New parts	Parts No.	Description	Destination	Ref. No.	Address	New parts	Parts No.	Description	Destination
L301			L92-0472-05	CHIP FERRITE		R112			RK73HB1J220J	CHIP R 22 J 1/16W	
L302-304			L92-0138-05	CHIP FERRITE		R113			RK73HB1J223J	CHIP R 22K J 1/16W	
L305			L92-0140-05	CHIP FERRITE		R114			RK73HB1J822J	CHIP R 8.2K J 1/16W	
X1			L77-3042-05	TCXO (12.8MHZ)		R116			RK73HB1J331J	CHIP R 330 J 1/16W	
X301			L78-1433-05	RESONATOR (14.746MHZ)		R117			RK73HB1J102J	CHIP R 1.0K J 1/16W	
XF201			L71-0619-05	MCF (38.85MHZ/6.5KH)		R119			RK73GB2A000J	CHIP R 0.0 J 1/10W	
CP1			RK75HA1J101J	CHIP-COM 100 J 1/16W		R120			RK73EB2ER39K	CHIP R 0.39 K 1/4W	
CP201			RK75HA1J104J	CHIP-COM 100K J 1/16W		R121			RK73HB1J123J	CHIP R 12K J 1/16W	
CP202			RK75HA1J474J	CHIP-COM 470K J 1/16W		R122			RK73HB1J153J	CHIP R 15K J 1/16W	
CP203			RK75HA1J104J	CHIP-COM 100K J 1/16W		R123			RK73EB2ER39K	CHIP R 0.39 K 1/4W	
CP204			RK75HA1J474J	CHIP-COM 470K J 1/16W		R124			RK73HB1J220J	CHIP R 22 J 1/16W	
CP301,302			RK75HA1J473J	CHIP-COM 47K J 1/16W		R125			RK73HB1J683J	CHIP R 68K J 1/16W	
CP303,304			RK75HA1J102J	CHIP-COM 1.0K J 1/16W		R126			RK73EB2ER39K	CHIP R 0.39 K 1/4W	
R1			RK73HB1J223J	CHIP R 22K J 1/16W		R127,128			RK73GH2A154D	CHIP R 150K D 1/10W	
R2			RK73HB1J103J	CHIP R 10K J 1/16W		R129,130			RK73GH2A334D	CHIP R 330K D 1/10W	
R3			RK73HB1J184J	CHIP R 180K J 1/16W		R131			RK73HB1J105J	CHIP R 1.0M J 1/16W	
R4			RK73HB1J563J	CHIP R 56K J 1/16W		R132			RK73HB1J473J	CHIP R 47K J 1/16W	
R5			RK73HB1J104J	CHIP R 100K J 1/16W		R133			RK73HB1J000J	CHIP R 0.0 J 1/16W	
R7			RK73HB1J000J	CHIP R 0.0 J 1/16W		R134			RK73HB1J563J	CHIP R 56K J 1/16W	
R8			RK73HB1J101J	CHIP R 100 J 1/16W		R135			RK73HB1J104J	CHIP R 100K J 1/16W	
R9			RK73HB1J222J	CHIP R 2.2K J 1/16W		R136			RK73HB1J474J	CHIP R 470K J 1/16W	
R10			RK73HB1J000J	CHIP R 0.0 J 1/16W		R137			RK73FB2B000J	CHIP R 0.0 J 1/8W	
R11			RK73HB1J274J	CHIP R 270K J 1/16W		R138			RK73GB2A151J	CHIP R 150 J 1/10W	
R12			RK73HB1J221J	CHIP R 220 J 1/16W		R140			RK73GB2A000J	CHIP R 0.0 J 1/10W	
R13			RK73HB1J101J	CHIP R 100 J 1/16W		R141			RK73HB1J000J	CHIP R 0.0 J 1/16W	
R14			RK73HB1J100J	CHIP R 10 J 1/16W		R201			RK73HB1J823J	CHIP R 82K J 1/16W	
R15			RK73HB1J561J	CHIP R 560 J 1/16W		R203			RK73HB1J472J	CHIP R 4.7K J 1/16W	
R16			RK73HB1J181J	CHIP R 180 J 1/16W		R204			RK73HB1J100J	CHIP R 10 J 1/16W	
R17			RK73HB1J182J	CHIP R 1.8K J 1/16W		R205			RK73HB1J823J	CHIP R 82K J 1/16W	
R18			RK73HB1J681J	CHIP R 680 J 1/16W		R206			RK73HB1J272J	CHIP R 2.7K J 1/16W	
R19			RK73HB1J223J	CHIP R 22K J 1/16W		R207			RK73HB1J332J	CHIP R 3.3K J 1/16W	
R20			RK73HB1J471J	CHIP R 470 J 1/16W		R208			RK73HB1J823J	CHIP R 82K J 1/16W	
R21,22			RK73HB1J103J	CHIP R 10K J 1/16W		R209			RK73HB1J332J	CHIP R 3.3K J 1/16W	
R26			RK73HB1J333J	CHIP R 33K J 1/16W		R210			RK73HB1J392J	CHIP R 3.9K J 1/16W	
R27			RK73HB1J684J	CHIP R 680K J 1/16W		R211			RK73HB1J101J	CHIP R 100 J 1/16W	
R28			RK73HB1J102J	CHIP R 1.0K J 1/16W		R212			RK73HB1J224J	CHIP R 220K J 1/16W	
R29			RK73HB1J154J	CHIP R 150K J 1/16W		R213			RK73HB1J391J	CHIP R 390 J 1/16W	
R30			RK73HB1J273J	CHIP R 27K J 1/16W		R214			RK73HB1J331J	CHIP R 330 J 1/16W	
R31			RK73HB1J274J	CHIP R 270K J 1/16W		R215			RK73HB1J222J	CHIP R 2.2K J 1/16W	
R32			RK73HB1J474J	CHIP R 470K J 1/16W		R216			RK73HB1J151J	CHIP R 150 J 1/16W	
R33,34			RK73HB1J101J	CHIP R 100 J 1/16W		R217			RK73HB1J332J	CHIP R 3.3K J 1/16W	
R35			RK73HB1J820J	CHIP R 82 J 1/16W		R218,219			RK73HB1J563J	CHIP R 56K J 1/16W	
R36			RK73HB1J101J	CHIP R 100 J 1/16W		R220			RK73HB1J000J	CHIP R 0.0 J 1/16W	
R37			RK73HB1J472J	CHIP R 4.7K J 1/16W		R221			RK73HB1J105J	CHIP R 1.0M J 1/16W	
R38			RK73HB1J154J	CHIP R 150K J 1/16W		R222			RK73HB1J220J	CHIP R 22 J 1/16W	
R39			RK73HB1J101J	CHIP R 100 J 1/16W		R223			RK73HB1J331J	CHIP R 330 J 1/16W	
R41			RK73HB1J562J	CHIP R 5.6K J 1/16W		R225			RK73HB1J683J	CHIP R 68K J 1/16W	
R42			RK73HB1J220J	CHIP R 22 J 1/16W		R227			RK73HB1J000J	CHIP R 0.0 J 1/16W	
R43			RK73HB1J471J	CHIP R 470 J 1/16W		R228			RK73FB2B000J	CHIP R 0.0 J 1/8W	
R45			RK73HB1J562J	CHIP R 5.6K J 1/16W					RK73HB1J102J	CHIP R 1.0K J 1/16W	
R101			RK73HB1J332J	CHIP R 3.3K J 1/16W		R301			RK73HH1J474D	CHIP R 470K D 1/16W	
R102			RK73HB1J273J	CHIP R 27K J 1/16W		R302			RK73GB2A000J	CHIP R 0.0 J 1/10W	
R103			RK73HB1J331J	CHIP R 330 J 1/16W		R303			RK73HB1J101J	CHIP R 100 J 1/16W	
R104			RK73HB1J560J	CHIP R 56 J 1/16W		R304			RK73HB1J334J	CHIP R 330K J 1/16W	
R105			RK73HB1J333J	CHIP R 33K J 1/16W		R305			RK73HH1J474D	CHIP R 470K D 1/16W	
R106			RK73HB1J331J	CHIP R 330 J 1/16W		R306			RK73HB1J184J	CHIP R 180K J 1/16W	
R107			RK73HB1J680J	CHIP R 68 J 1/16W		R307			RK73GB2A271J	CHIP R 270 J 1/10W	
R109			RK73HB1J000J	CHIP R 0.0 J 1/16W		R308			RK73GB2A221J	CHIP R 220 J 1/10W	
R111			RK73HB1J473J	CHIP R 47K J 1/16W		R309,310			RK73GB2A000J	CHIP R 0.0 J 1/10W	
						R313			RK73HB1J102J	CHIP R 1.0K J 1/16W	

PARTS LIST

TX-RX UNIT (X57-7580-11)

Ref. No.	Address	New parts	Parts No.	Description	Destination	Ref. No.	Address	New parts	Parts No.	Description	Destination
R314,315			RK73HB1J103J	CHIP R 10K J 1/16W		MIC301	2A		T91-0651-15	MIC ELEMENT (ECM)	
R316			RK73HB1J222J	CHIP R 2.2K J 1/16W		D3,4			1SV325F	VARIABLE CAPACITANCE DIODE	
R317			RK73HB1J472J	CHIP R 4.7K J 1/16W		D6			1SV325F	VARIABLE CAPACITANCE DIODE	
R318			RK73HB1J182J	CHIP R 1.8K J 1/16W		D8			1SV325F	VARIABLE CAPACITANCE DIODE	
R319			RK73HB1J000J	CHIP R 0.0 J 1/16W		D9			KDV214E-P	DIODE	
R320			RK73HB1J123J	CHIP R 12K J 1/16W		D10			MC2858	DIODE	
R321			RK73HB1J103J	CHIP R 10K J 1/16W		D101			UDZW5.1(B)	ZENER DIODE	
R322,323			RK73HB1J102J	CHIP R 1.0K J 1/16W		D103			HSC277	DIODE	
R324,325			RK73HB1J472J	CHIP R 4.7K J 1/16W		D104			HVC131	DIODE	
R340-342			RK73HB1J103J	CHIP R 10K J 1/16W		D106			HVC131	DIODE	
R344			RK73HB1J474J	CHIP R 470K J 1/16W		D201-205			HVC355B	VARIABLE CAPACITANCE DIODE	
R345			RK73HB1J273J	CHIP R 27K J 1/16W		D301			GN1G	DIODE	
R347			RK73GB2A000J	CHIP R 0.0 J 1/10W		D302			HRC0203C	DIODE	
R348			RK73HB1J102J	CHIP R 1.0K J 1/16W		D306			KDR731	DIODE	
R349			RK73HB1J105J	CHIP R 1.0M J 1/16W		D307			MC2850	DIODE	
R350			RK73HB1J124J	CHIP R 120K J 1/16W		D308,309			KDR731	DIODE	
R351			RK73HB1J334J	CHIP R 330K J 1/16W		IC1			MB15A02PFV2E1	MOS-IC	
R352			RK73HB1J154J	CHIP R 150K J 1/16W		IC101			BA2904FVM	MOS-IC	
R353			RK73HB1J123J	CHIP R 12K J 1/16W		IC201			TA31136FNG	MOS-IC	
R354			RK73HB1J334J	CHIP R 330K J 1/16W		IC301			BD4840FVE	MOS-IC	
R355			RK73HB1J124J	CHIP R 120K J 1/16W		IC303			XC6209B502PR	MOS-IC	
R356			RK73HB1J472J	CHIP R 4.7K J 1/16W		IC304			XC6209B502MR	MOS-IC	
R357			RK73HB1J563J	CHIP R 56K J 1/16W		IC305			BR24L16F-W	ROM IC	
R358			RK73HB1J474J	CHIP R 470K J 1/16W		IC306	*		RSF212CCKCME	MICRO CONTROL UNIT	
R359			RK73HB1J473J	CHIP R 47K J 1/16W		IC308			AQUA-L	MOS-IC	
R360			RK73HB1J562J	CHIP R 5.6K J 1/16W		IC309			TA7368FG	MOS-IC	
R361			RK73GB2A000J	CHIP R 0.0 J 1/10W		Q1			KTC4075E(Y,GR)	TRANSISTOR	
R362			RK73HB1J184J	CHIP R 180K J 1/16W		Q2			2SC4774	TRANSISTOR	
R363,364			RK73HB1J104J	CHIP R 100K J 1/16W		Q3			2SC5636	TRANSISTOR	
R365			RK73HB1J332J	CHIP R 3.3K J 1/16W		Q4,5			2SK1875-F(V)	FET	
R366			RK73HB1J154J	CHIP R 150K J 1/16W		Q6			KTC4075E(Y,GR)	TRANSISTOR	
R367			RK73HB1J393J	CHIP R 39K J 1/16W		Q7,8			RT1P430U	TRANSISTOR	
R368			RK73GB2A000J	CHIP R 0.0 J 1/10W		Q9			2SC5636	TRANSISTOR	
R369			RK73HB1J823J	CHIP R 82K J 1/16W		Q10			KTC4075E(Y,GR)	TRANSISTOR	
R370			RK73HB1J102J	CHIP R 1.0K J 1/16W		Q11			2SC5636	TRANSISTOR	
R371			RK73HB1J822J	CHIP R 8.2K J 1/16W		Q101			2SC5636	TRANSISTOR	
R372			RK73HB1J000J	CHIP R 0.0 J 1/16W		Q102			2SC5455-A	TRANSISTOR	
R373			RK73HB1J224J	CHIP R 220K J 1/16W		Q103			RD01MUS1-T113	FET	
R374			RK73HB1J153J	CHIP R 15K J 1/16W		Q104			RT1N441U	TRANSISTOR	
R375			RK73HB1J182J	CHIP R 1.8K J 1/16W		Q105			2SK879-F(Y)	FET	
R376			RK73HB1J471J	CHIP R 470 J 1/16W		Q106			RD02MUS1BT112	FET	
R377			RK73HB1J473J	CHIP R 47K J 1/16W		Q107			RT1N441U	TRANSISTOR	
R378			RK73HB1J561J	CHIP R 560 J 1/16W		Q108			2SK1824-A	FET	
R379			RK73HB1J102J	CHIP R 1.0K J 1/16W		Q109			RT1P441U	TRANSISTOR	
R380			RK73HB1J474J	CHIP R 470K J 1/16W		Q201			RT1P441U	TRANSISTOR	
R381			RK73HB1J151J	CHIP R 150 J 1/16W		Q202			2SC4774	TRANSISTOR	
R383			RK73HB1J563J	CHIP R 56K J 1/16W		Q203,204			3SK318	FET	
R384			RK73HB1J333J	CHIP R 33K J 1/16W		Q301,302			RT1N441U	TRANSISTOR	
R385			RK73GB2A101J	CHIP R 100 J 1/10W		Q303			RT1P141U	TRANSISTOR	
R387			RK73HB1J104J	CHIP R 100K J 1/16W		Q304			DTB723YE	DIGITAL TRANSISTOR	
R388			RK73HB1J101J	CHIP R 100 J 1/16W		Q305,306			2SC4919	TRANSISTOR	
R389			RK73HB1J000J	CHIP R 0.0 J 1/16W		Q307			RT1N441U	TRANSISTOR	
R390			RK73GB2A000J	CHIP R 0.0 J 1/10W		Q308			KTC4075E(Y,GR)	TRANSISTOR	
R391			RK73HB1J102J	CHIP R 1.0K J 1/16W		Q310			2SC4116(GR)F	TRANSISTOR	
R393			RK73GB2A000J	CHIP R 0.0 J 1/10W		Q311			2SA1586(Y,GR)F	TRANSISTOR	
R394			RK73HB1J473J	CHIP R 47K J 1/16W		Q312			RT1N441U	TRANSISTOR	
R398			RK73HB1J000J	CHIP R 0.0 J 1/16W		Q313			2SB1694	TRANSISTOR	
VR1			R32-0736-05	SEMI FIXED VARIABLE RESISTOR		Q314			RT1N441U	TRANSISTOR	
S1-3			S70-0414-05	TACT SWITCH		Q315,316			2SK3577-A	FET	

TK-3300

PARTS LIST

TX-RX UNIT (X57-7580-11)

Ref. No.	Address	New parts	Parts No.	Description	Destination	Ref. No.	Address	New parts	Parts No.	Description	Destination
TH101			B57331V2104J	THERMISTOR							
TH201			B57331V2104J	THERMISTOR							

EXPLODED VIEW

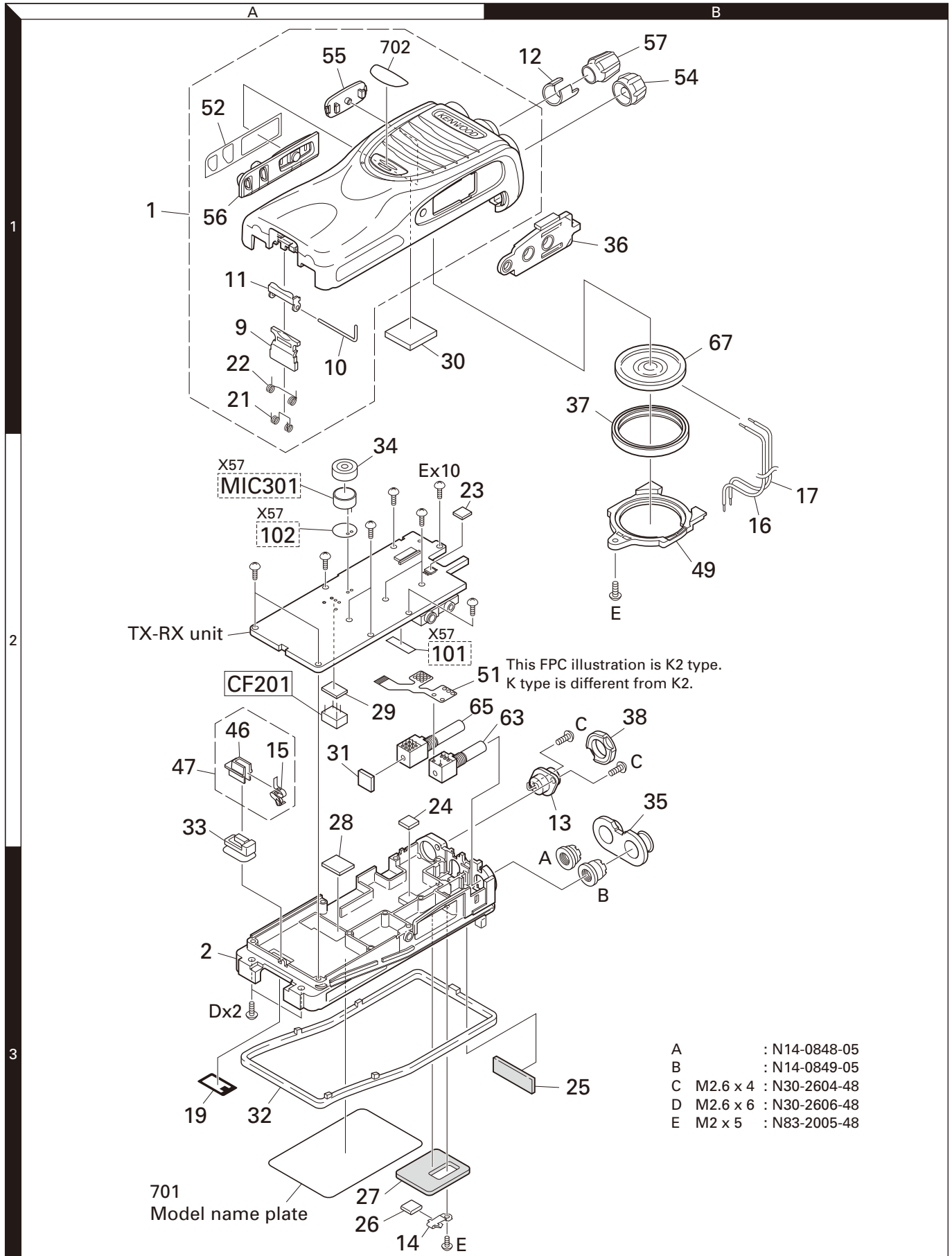

Parts with the exploded numbers larger than 700 are not supplied.

If a part reference number is listed in a box on the exploded view of the PCB, that part does not come with the PCB. These parts must be ordered separately.

PACKING

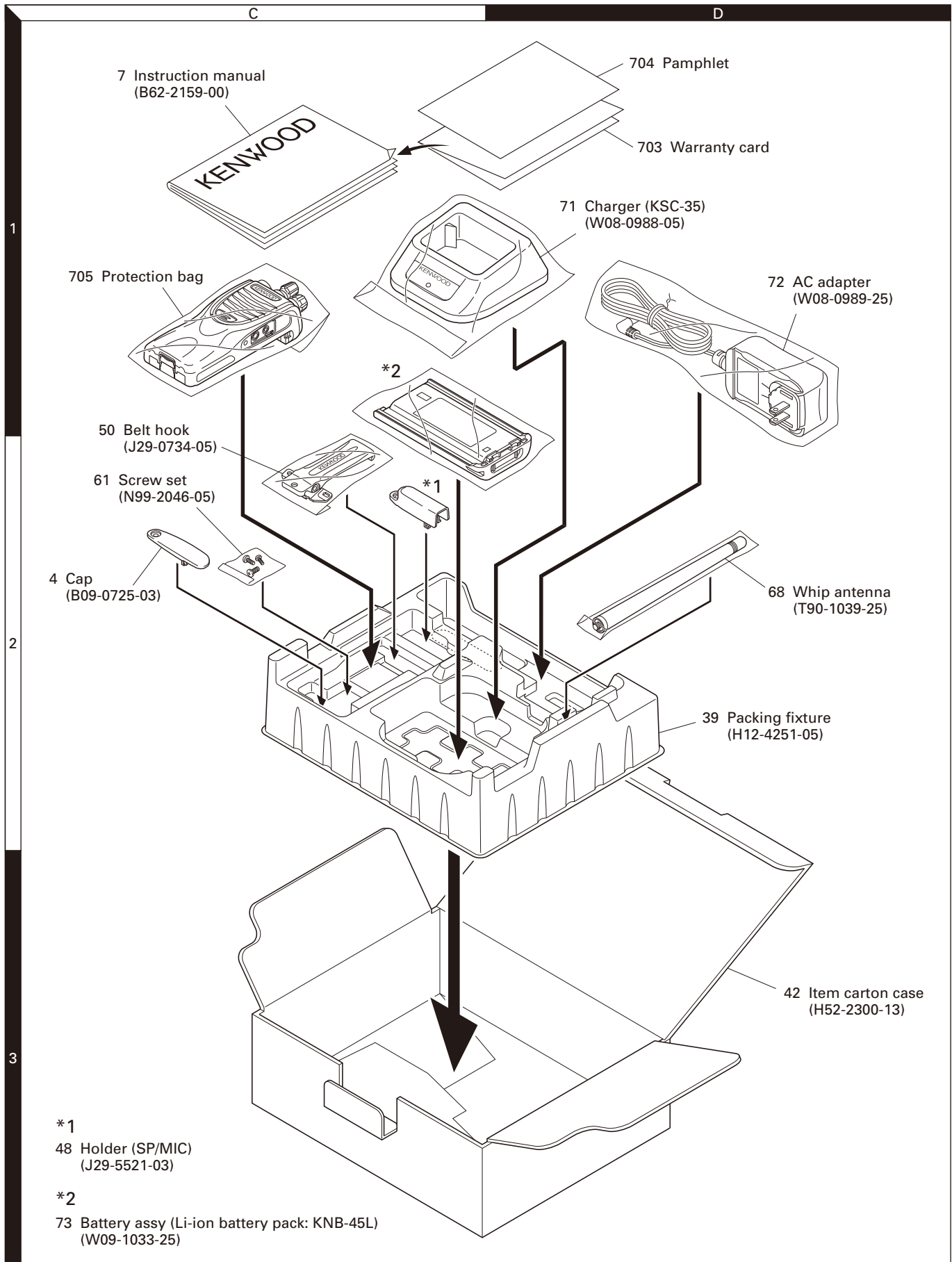

Parts with the exploded numbers larger than 700 are not supplied.

ADJUSTMENT

Test Equipment Required for Alignment

Test Equipment	Major Specifications	
1. Standard Signal Generator (SSG)	Frequency Range Modulation Output	450 to 470MHz Frequency modulation and external modulation -127dBm/0.1 μ V to greater than -47dBm/1mV
2. RF Power Meter	Input Impedance Operation Frequency Measurement Range	50 Ω 450 to 470MHz Vicinity of 10W
3. Deviation Meter	Frequency Range	450 to 470MHz
4. Digital Volt Meter (DVM)	Measuring Range Input Impedance	10mV to 10V DC High input impedance for minimum circuit loading
5. Oscilloscope		DC through 30MHz
6. High Sensitivity Frequency Counter	Frequency Range Frequency Stability	10Hz to 1000MHz 0.2ppm or less
7. DC Ammeter		5A
8. AF Volt Meter (AF VTVM)	Frequency Range Voltage Range	50Hz to 10kHz 1mV to 10V
9. Audio Generator (AG)	Frequency Range Output	50Hz to 5kHz or more 0 to 1V
10. Distortion Meter	Capability Input Level	3% or less at 1kHz 50mV to 10Vrms
11. Spectrum Analyzer	Measuring Range	DC to 1GHz or more
12. Tracking Generator	Center frequency Output Voltage	50kHz to 600MHz 100mV or more
13. 8 Ω Dummy Load		Approx. 8 Ω , 3W
14. Regulated Power Supply		5V to 10V, approx. 3A Useful if ammeter equipped

■ Antenna connector adapter

The antenna connector of this transceiver uses an SMA terminal.

Use an antenna connector adapter [SMA(f) – BNC(f) or SMA(f) – N(f)] for adjustment. (The adapter is not provided as an option, so buy a commercially-available one.)

■ Repair Jig (Chassis)

Use jig (part No.: A10-4215-03) for repairing the transceiver. Place the TX-RX unit on the jig and fit it with screws.

The jig facilitates the voltage check and protects the final amplifier FET when the voltage on the flow side of the TX-RX unit is checked during repairs.

■ Battery Jig (W05-1011-00)

Connect the power cable properly between the battery jig installed in the transceiver and the power supply, and be sure output voltage and the power supply polarity prior to switching the power supply ON, otherwise over voltage and reverse connection may damage the transceiver, or the power supply or both.

Note: When using the battery jig, you must measure the voltage at the terminals of the battery jig. Otherwise, a slight voltage drop may occur within the power cable, between the power supply and the battery jig, especially while the transceiver transmits.

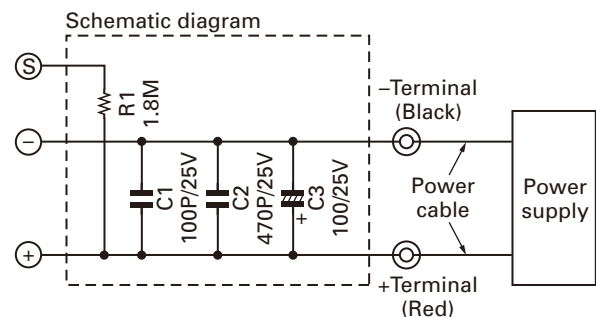
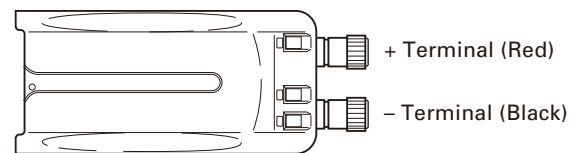

ADJUSTMENT

Frequency and Signaling

The transceiver has been adjusted for the frequencies shown in the following table. When required, re-adjust them following the adjustment procedure to obtain the frequencies you want in actual operation.

■ Frequency (MHz)

Channel No.	RX Frequency	TX Frequency
1	460.050	460.100
2	450.050	450.100
3	469.950	469.900
4	460.000	460.000
5	460.200	460.200
6	460.400	460.400
7~16	-	-

■ Signaling

Signaling No.	RX	TX
1	None	None
2	None	100Hz Square Wave
3	QT 67.0Hz	QT 67.0Hz
4	QT 151.4Hz	QT 151.4Hz
5	QT 250.3Hz	QT 250.3Hz
6	DQT D023N	DQT D023N
7	DQT D754I	DQT D754I
8	DTMF Decode [159D]	DTMF Encode [159D]
9	None	DTMF Tone 9

Preparations for Tuning the Transceiver

Before attempting to tune the transceiver, connect the unit to a suitable power supply.

Whenever the transmitter is tuned, the unit must be connected to a suitable dummy load (i.e. power meter).

The speaker output connector must be terminated with a 8Ω dummy load and connected to an AC voltmeter and an audio distortion meter or a SINAD measurement meter at all times during tuning.

■ Adjustment frequency

TEST CH	RX	TX
Center	460.050MHz	460.100MHz
Low	450.050MHz	450.100MHz
High	469.950MHz	469.900MHz
Low'	455.050MHz	455.100MHz
High'	465.050MHz	465.100MHz

■ List of FPU for transceiver

Model	Type	FPU
TK-3300	K,K2	KPG-120D

The figure below is a reference chart of Receiver section (1.BPF Wave Adjust)

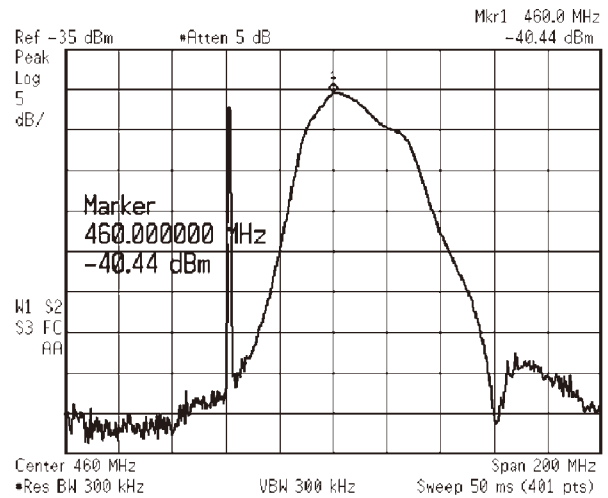

Fig. 1 Center frequency

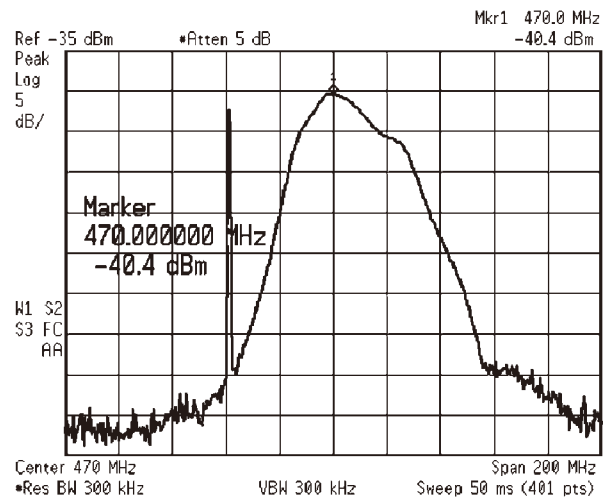

Fig. 2 High-edge frequency

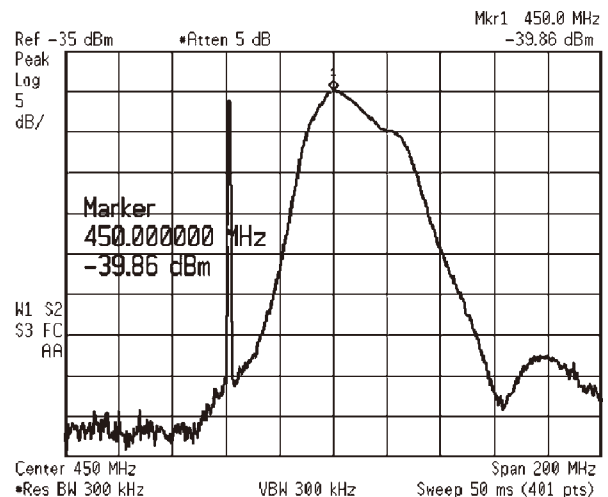
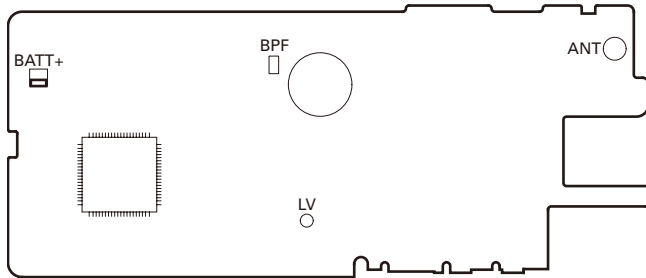

Fig. 3 Low-edge frequency

ADJUSTMENT

Adjustment Points

■ Component side view



BPF: BPF Wave Adjust
 LV (CV): VCO lock voltage
 BATT+: Battery Warning Level

■ Foil side view

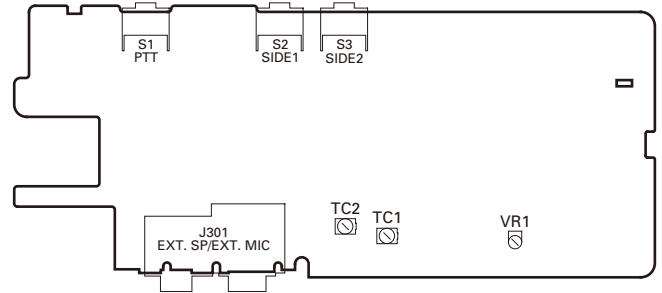

TC1 : VCO lock voltage (RX)
 TC2 : VCO lock voltage (TX)
 VR1 : Frequency adjustment

Common Section

Item	Condition	Measurement			Adjustment			Specifications / Remarks
		Test-equipment	Unit	Terminal	Unit	Parts	Method	
1. Setting	1) BATT terminal vorage: 7.5V 2) SSG standard modulation [Wide] MOD: 1kHz, DEV: 3kHz [Narrow] MOD: 1kHz, DEV: 1.5kHz							
2. VCO lock voltage RX	1) CH: High	Power meter DVM	TX-RX	ANT LV (CV)	TX-RX	TC1	3.5V	±0.1V
	2) CH: Low						Check	0.6V or more
3. VCO lock voltage TX	3) CH: High PTT: ON				TX-RX	TC2	3.5V	±0.1V
	4) CH: Low PTT: ON						Check	0.6V or more

Transmitter Section

Item	Condition	Measurement			Adjustment			Specifications / Remarks
		Test-equipment	Unit	Terminal	Unit	Parts	Method	
1. Frequency Adjust	1) CH: High PTT: ON	f. counter		ANT	TX-RX	VR1	High frequency	±50Hz
2. High Transmit Power	1) TEST CH: Low, Low', Center, High', High (5 points) BATT terminal voltage: 7.5V PTT: ON	Power meter Ammeter				FPU		2.0W±0.1W 1.2A or less
3. Low Transmit Power	1) TEST CH: Low, Low', Center, High', High (5 points) BATT terminal voltage: 7.5V PTT: ON							1.0W±0.1W 1.0A or less

ADJUSTMENT

Item	Condition	Measurement			Adjustment			Specifications / Remarks
		Test-equipment	Unit	Terminal	Unit	Parts	Method	
4. Maximum Deviation [Wide]	1) TEST CH: Center, Low, High (3 points) AG: 1kHz/150mV Deviation meter filter LPF: 15kHz HPF: OFF PTT: ON	Power meter Deviation meter meter Oscilloscope AG AF VTVM		ANT SP/MIC connector		FPU	4.4kHz (According to the lager +, -)	±80Hz
	[Narrow]						2) TEST CH: Center PTT: ON	
5. DQT Balance [Wide]	1) TEST CH: Center, Low, High (3 points) Deviation meter filter LPF: 3kHz HPF: OFF PTT: ON						Make the demodulation wave into square waves.	
	[Narrow]						2) TEST CH: Center PTT: ON	
6. QT Fine Deviation [Wide]	1) TEST CH: Center, Low, High (3 points) Deviation meter filter LPF: 3kHz HPF: OFF PTT: ON						0.75kHz	±40Hz
	[Narrow]						2) TEST CH: Center PTT: ON	
7. DQT Fine Deviation [Wide]	1) TEST CH: Center, Low, High (3 points) Deviation meter filter LPF: 3kHz HPF: OFF PTT: ON						0.75kHz	±40Hz
	[Narrow]						2) TEST CH: Center PTT: ON	
8. DTMF Fine Deviation [Wide]	1) TEST CH: Center Deviation meter filter LPF: 15kHz HPF: OFF PTT: ON						3.0kHz	±100Hz
	[Narrow]						2) TEST CH: Center PTT: ON	
9. MSK Fine Deviation [Wide]	1) TEST CH: Center Deviation meter filter LPF: 15kHz HPF: OFF PTT: ON						3.0kHz	±100Hz
	[Narrow]						2) TEST CH: Center PTT: ON	

ADJUSTMENT

Receiver Section

Item	Condition	Measurement			Adjustment			Specifications / Remarks
		Test-equipment	Unit	Terminal	Unit	Parts	Method	
1. BPF Wave Adjust	1) Center frequency Spectrum analyzer setting Center-f: 460MHz Span: 200MHz RBW: 100kHz VBW: 10kHz ATT: 10dB 2) High-edge frequency Spectrum analyzer setting Center-f: 470MHz 3) Low-edge frequency Spectrum analyzer setting Center-f: 450MHz	SSG Spectrum analyzer	TX-RX	ANT BPF		FPU	Adjust the waveform as shown to the Fig. 1~3.	
2. Sensitivity [Wide]	1) TEST CH: Low, Center, High (3 points) SSG output : -117dBm (0.3 μ V) SSG MOD: 3.0kHz	SSG DVM Oscilloscope AF VTVM		ANT SP/MIC connector			Check	12dB SINAD or more
[Narrow]	2) TEST CH: Center SSG output : -116dBm (0.35 μ V) SSG MOD: 1.5kHz							
3. Squelch Open [Wide]	1) TEST CH: Center, Low, High (3 points) SSG output : -123dBm (0.16 μ V) SSG MOD: 3.0kHz					FPU	Write	
[Narrow]	2) TEST CH: Center SSG output : -122dBm (0.18 μ V) SSG MOD: 1.5kHz							
4. Squelch Tight [Wide]	1) TEST CH: Center, Low, High (3 points) SSG output : -117dBm (0.3 μ V) SSG MOD: 3.0kHz							
[Narrow]	2) TEST CH: Center SSG output : -116dBm (0.35 μ V) SSG MOD: 1.5kHz							
5. Battery Warning Level	1) BATT terminal voltage: 5.9V	SSG DVM	TX-RX	ANT BATT terminal			Write	BATT terminal voltage: 5.9V

TK-3300 PC BOARD

TX-RX UNIT (X57-7580-11) Component side view (J79-0187-19)

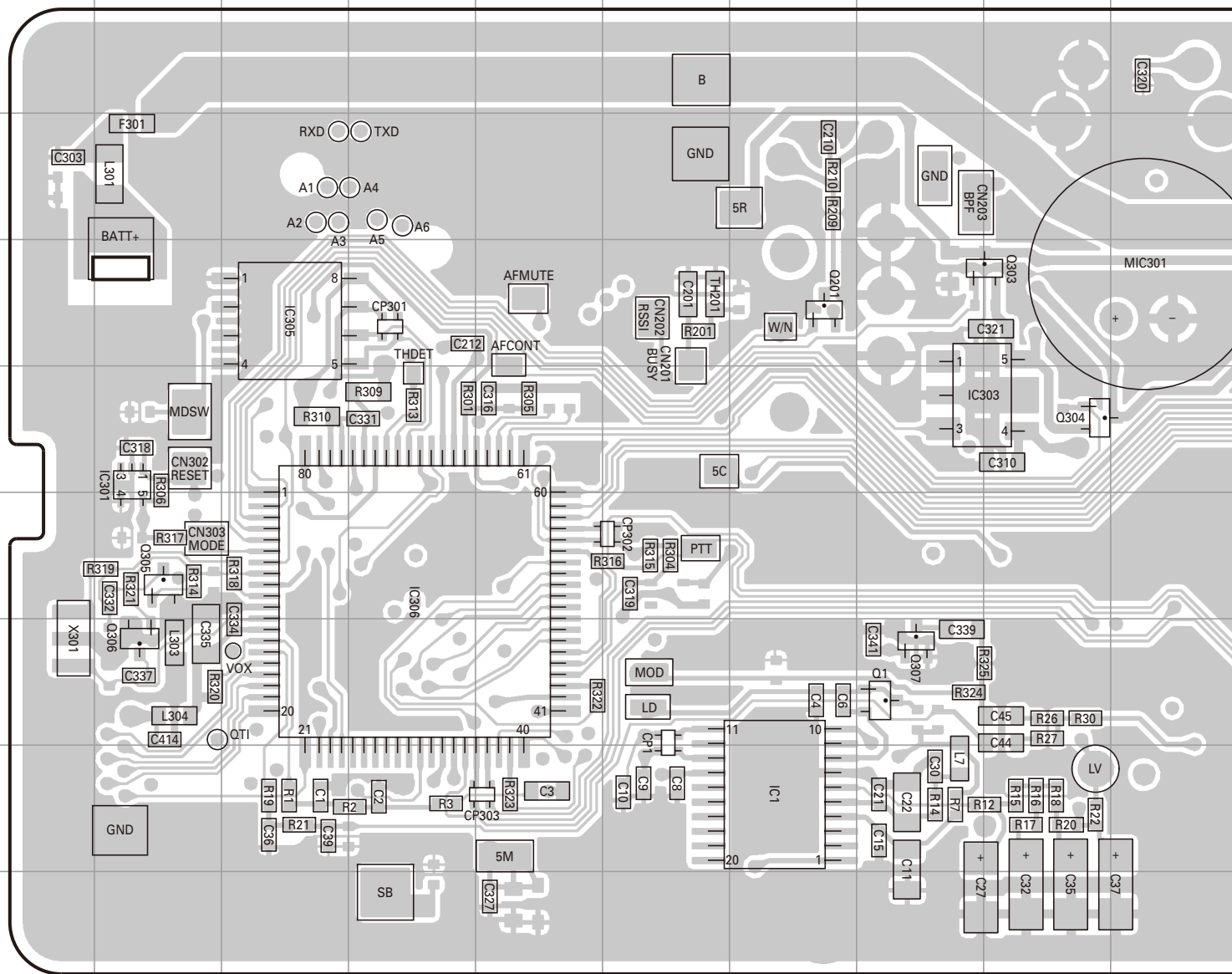

Ref. No.	Address	Ref. No.	Address	Ref. No.	Address	Ref. No.	Address
IC1	9G	Q104	4N	Q303	5I	Q315	8O
IC101	4N	Q105	5N	Q304	6I	Q316	8O
IC301	6B	Q107	3M	Q305	7B	D101	4M
IC303	6H	Q108	3M	Q306	8B	D303	8S
IC305	5C	Q109	4M	Q307	8H	D304	8S
IC306	7D	Q201	5G	Q312	8P		
IC309	7O	Q301	6P	Q313	7P		
Q1	8H	Q302	6P	Q314	8O		

PC BOARD TK-3300

TX-RX UNIT (X57-7580-11) Component side view (J79-0187-19)

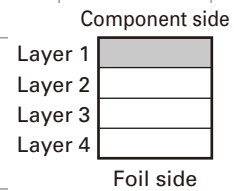
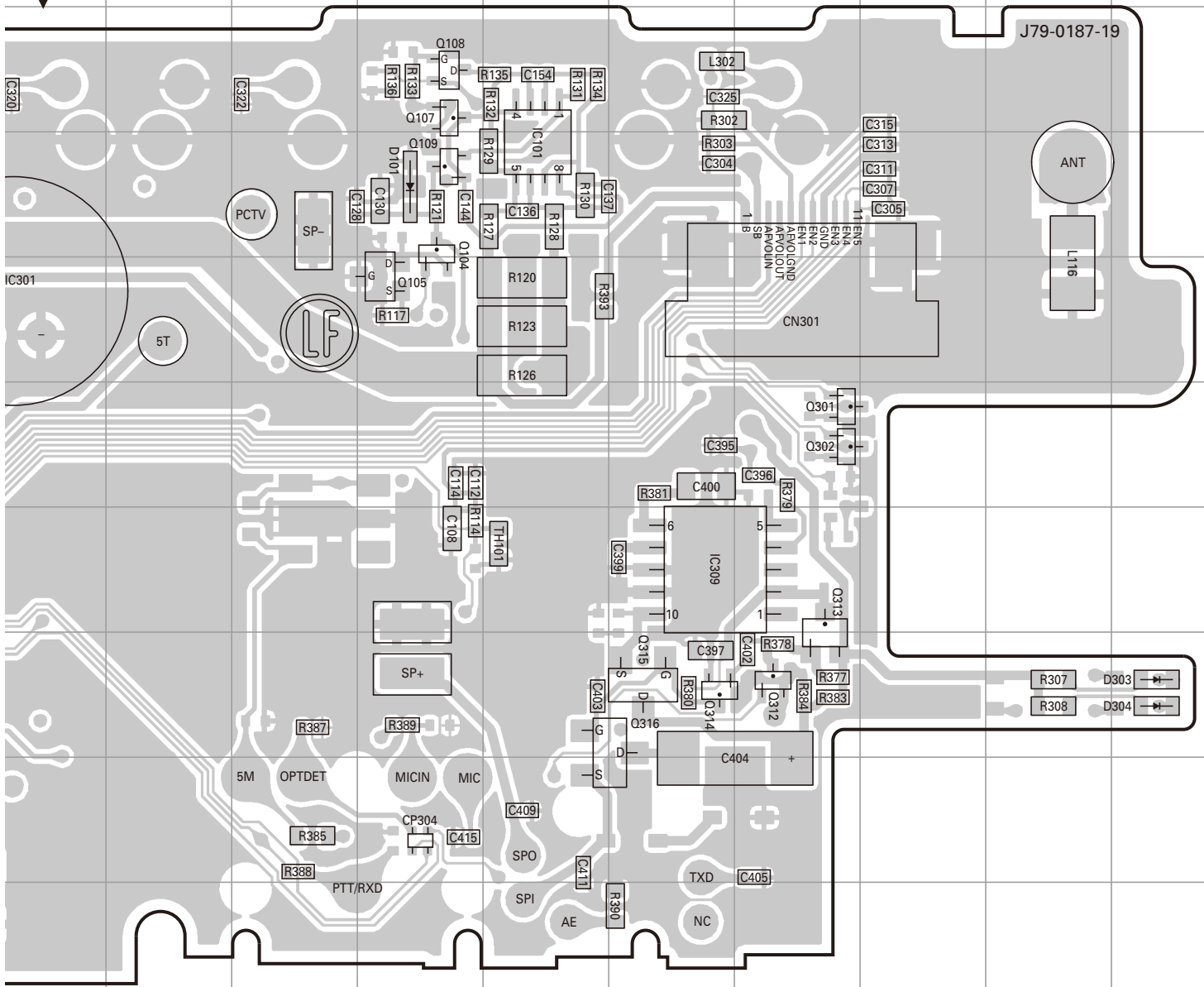

TK-3300 PC BOARD

TX-RX UNIT (X57-7580-11) Foil side view (J79-0187-19)

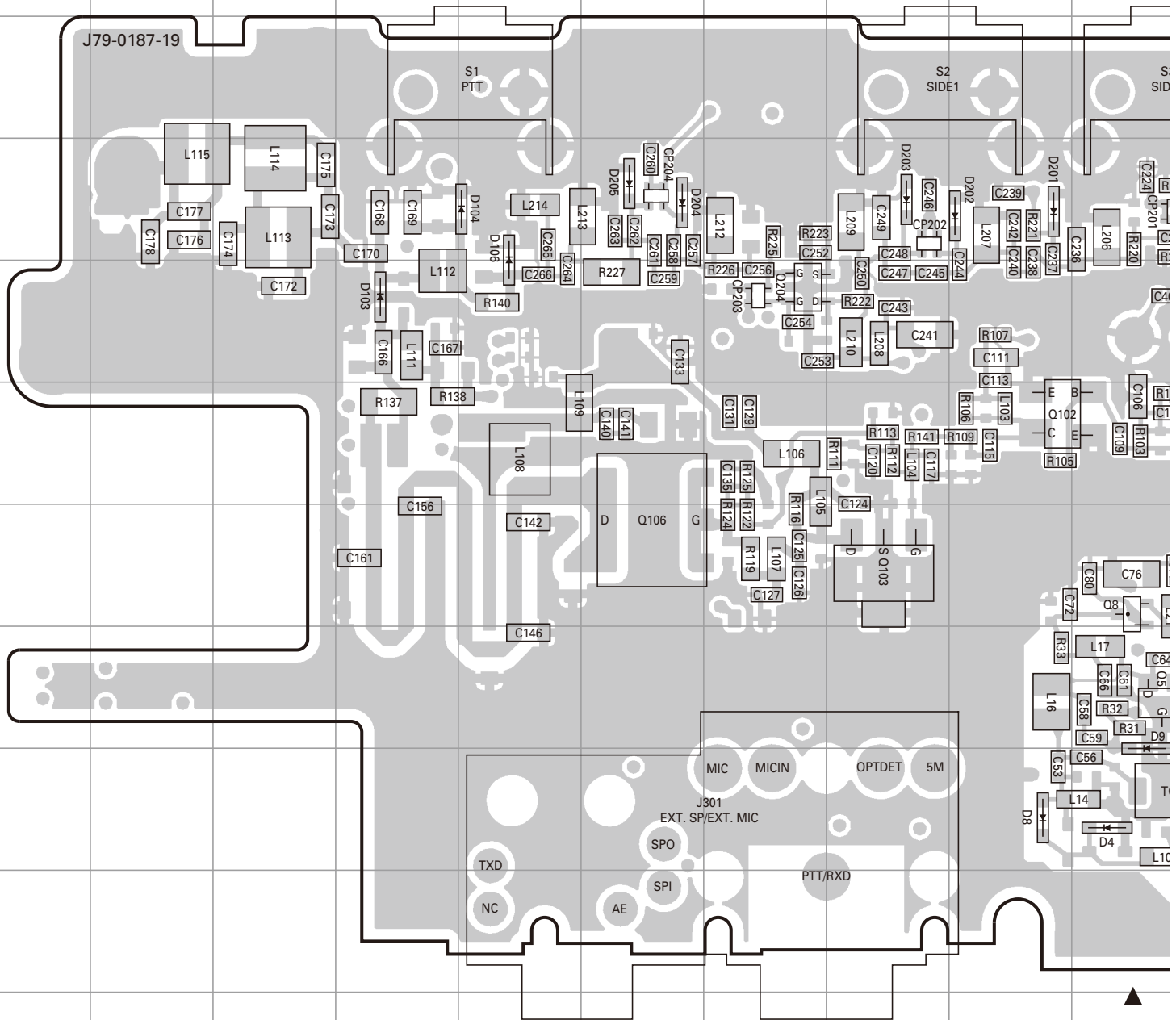

Ref. No.	Address	Ref. No.	Address	Ref. No.	Address	Ref. No.	Address	Ref. No.	Address
IC201	6N	Q8	7J	Q203	4K	D9	8J	D205	4F
IC304	9P	Q9	7K	Q204	5G	D10	5L	D301	4R
IC308	8P	Q10	7K	Q308	7R	D103	5D	D302	10P
Q2	8N	Q11	6K	Q310	7R	D104	4E	D306	8R
Q3	7L	Q101	6K	Q311	7R	D106	4E	D307	8Q
Q4	9L	Q102	6I	D3	10K	D201	4I	D308	7Q
Q5	8J	Q103	7H	D4	9J	D202	4I	D309	7Q
Q6	7K	Q106	7F	D6	10K	D203	4H		
Q7	8K	Q202	5N	D8	9I	D204	4F		

PC BOARD TK-3300

TX-RX UNIT (X57-7580-11)
Foil side view (J79-0187-19)

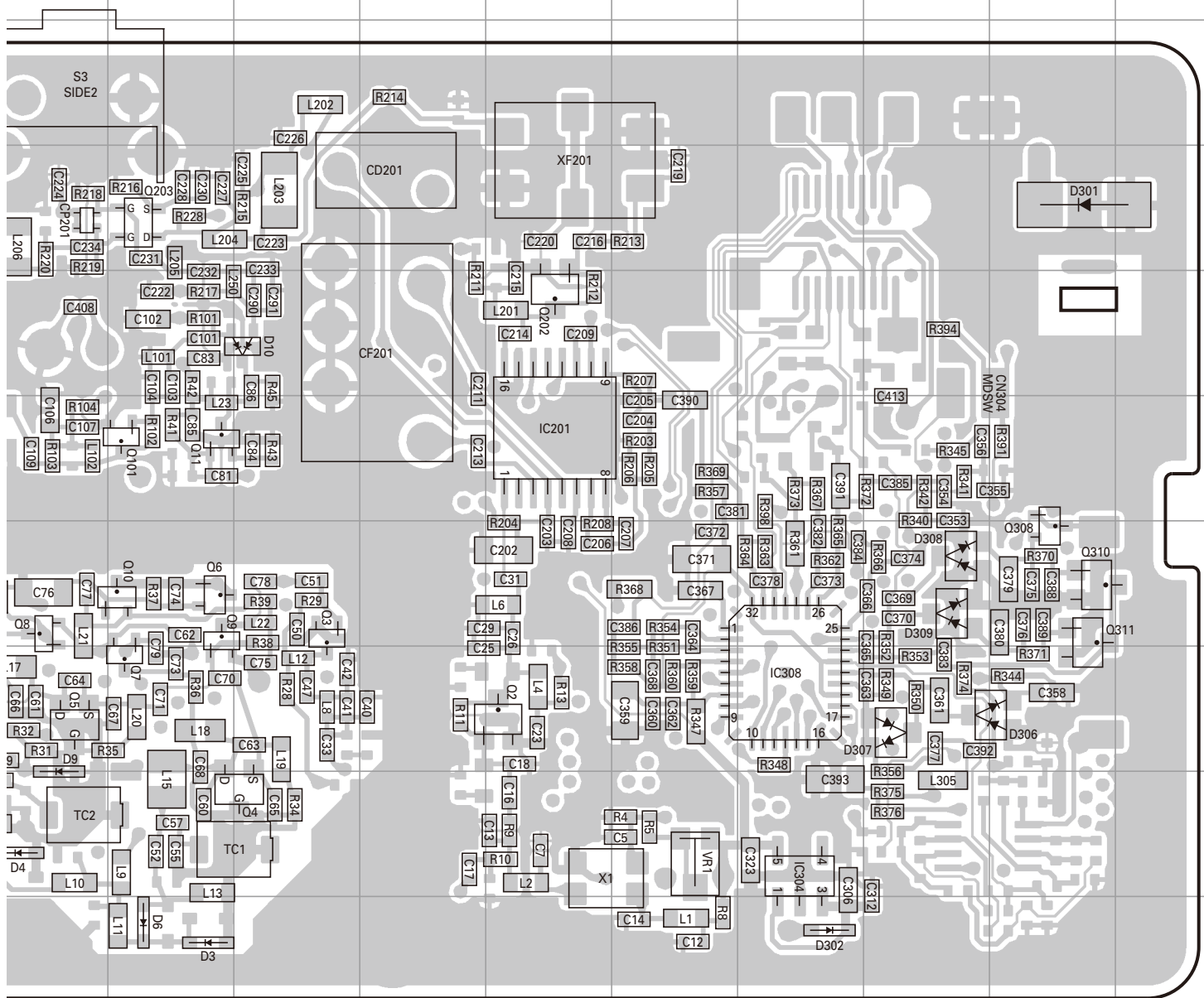

TK-3300 SCHEMATIC DIAGRAM

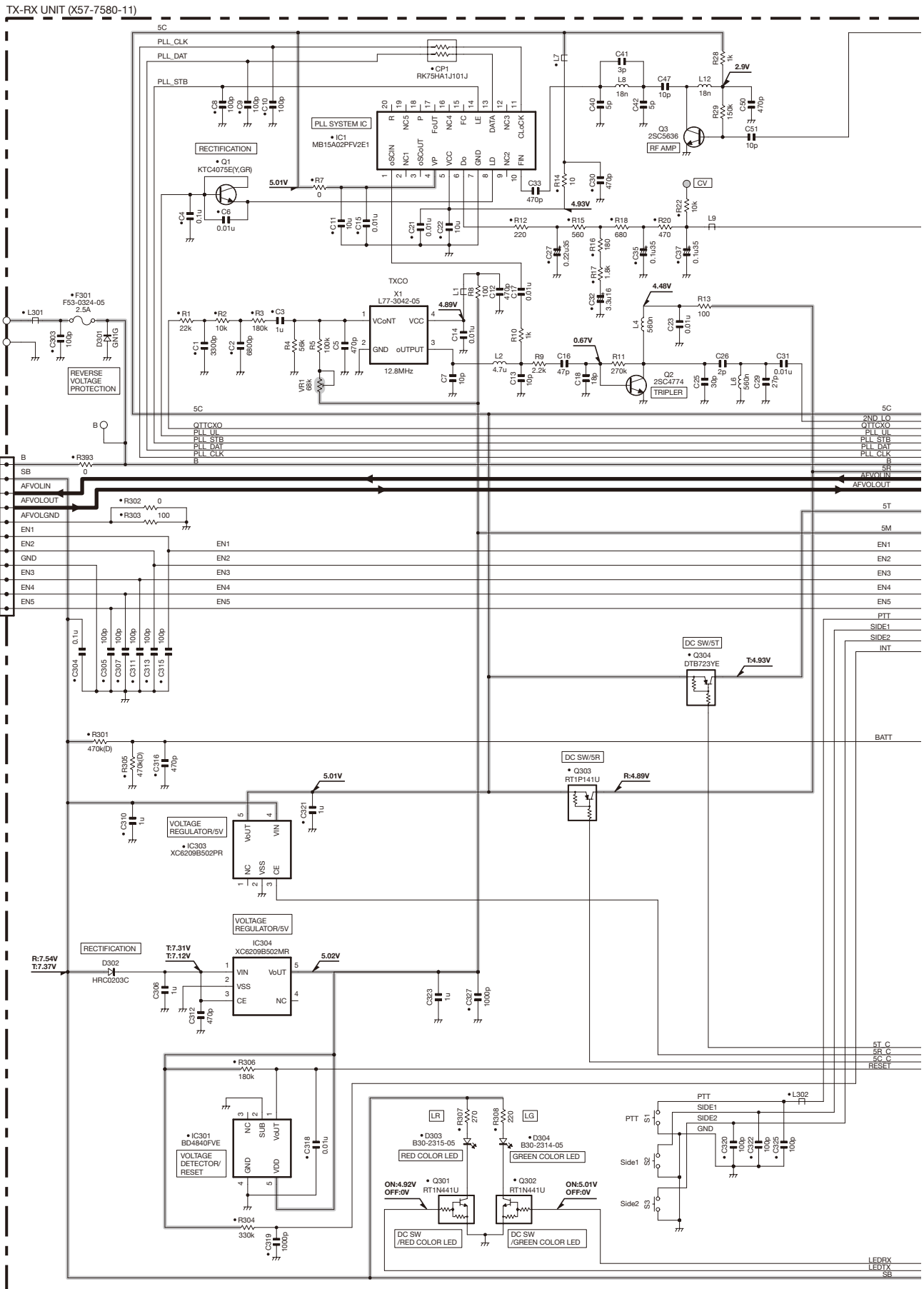

SCHEMATIC DIAGRAM TK-3300

TX-RX UNIT (X57-7580-11)

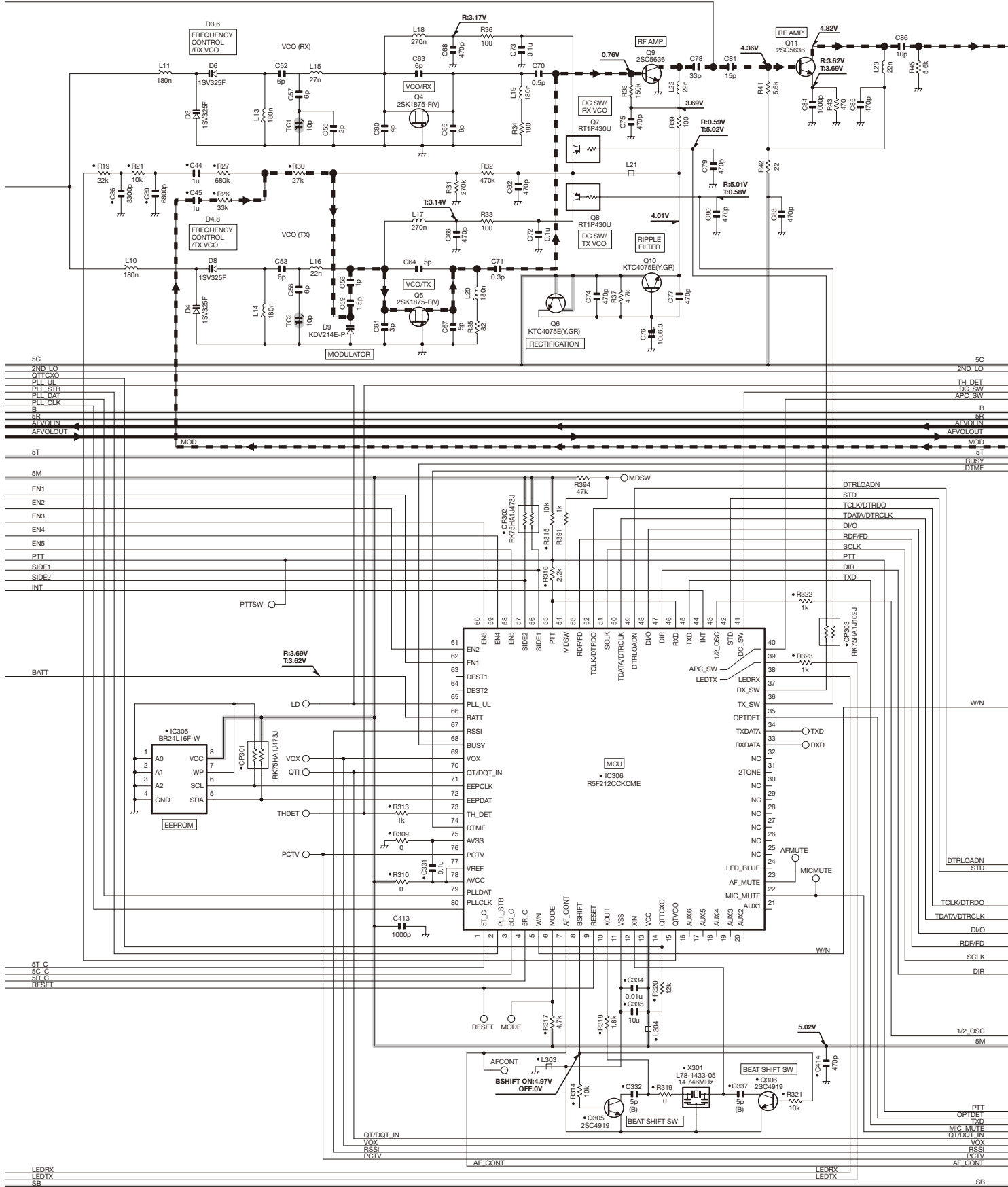

TK-3300 SCHEMATIC DIAGRAM

TX-RX UNIT (X57-7580-11)

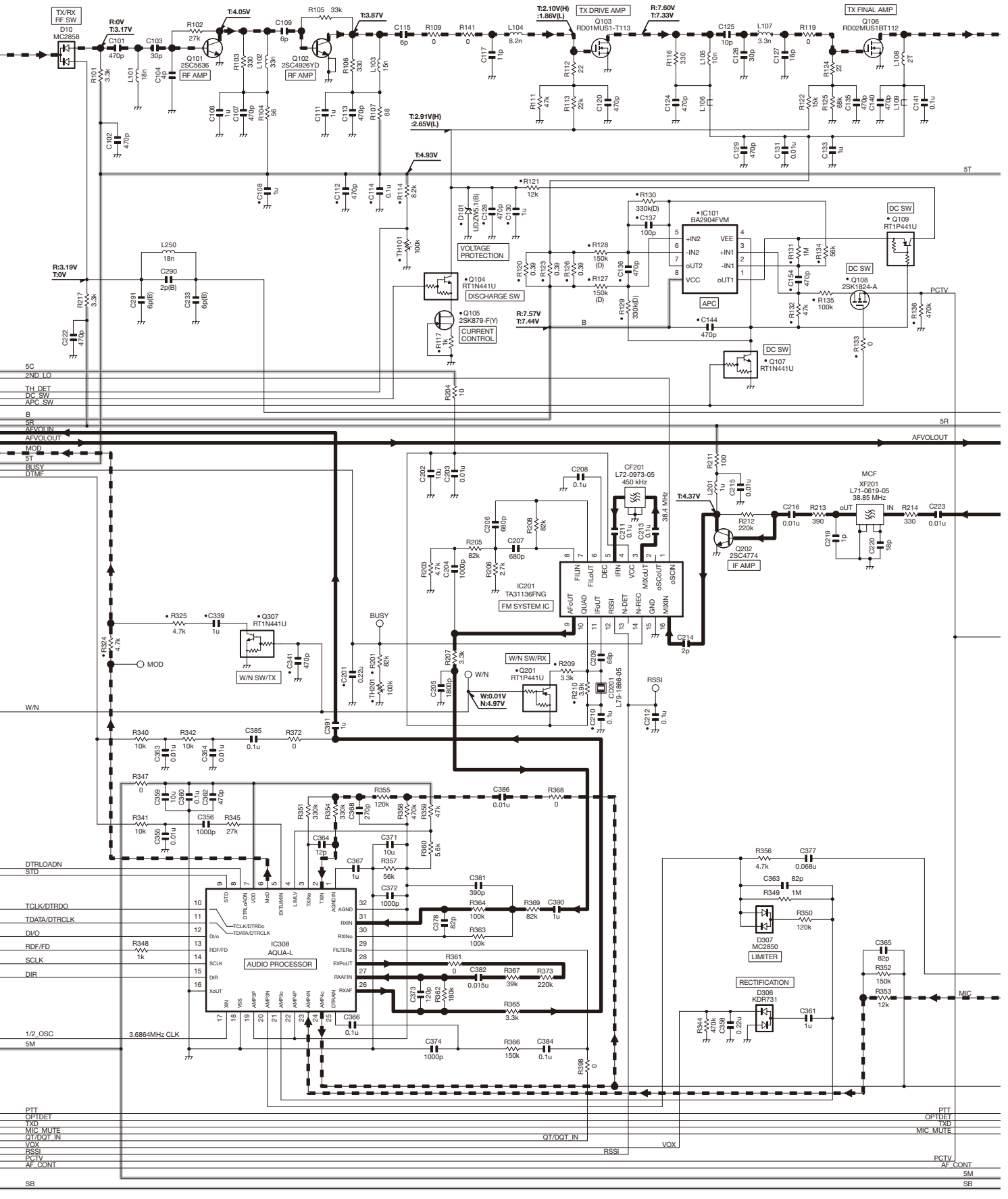

SCHEMATIC DIAGRAM TK-3300

TX-RX UNIT (X57-7580-11)

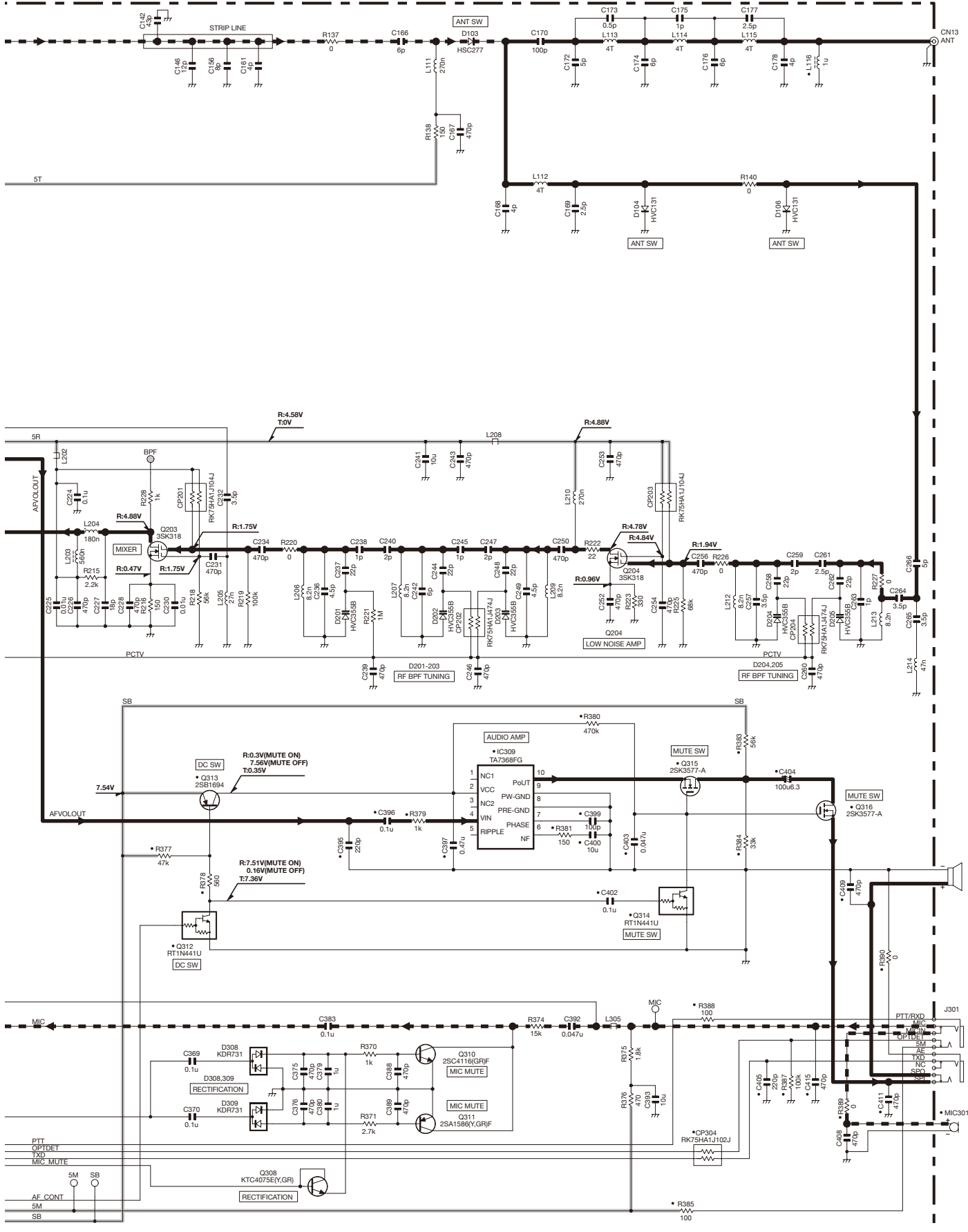

Note : The components marked with a dot (•) are parts of layer 1.

BLOCK DIAGRAM

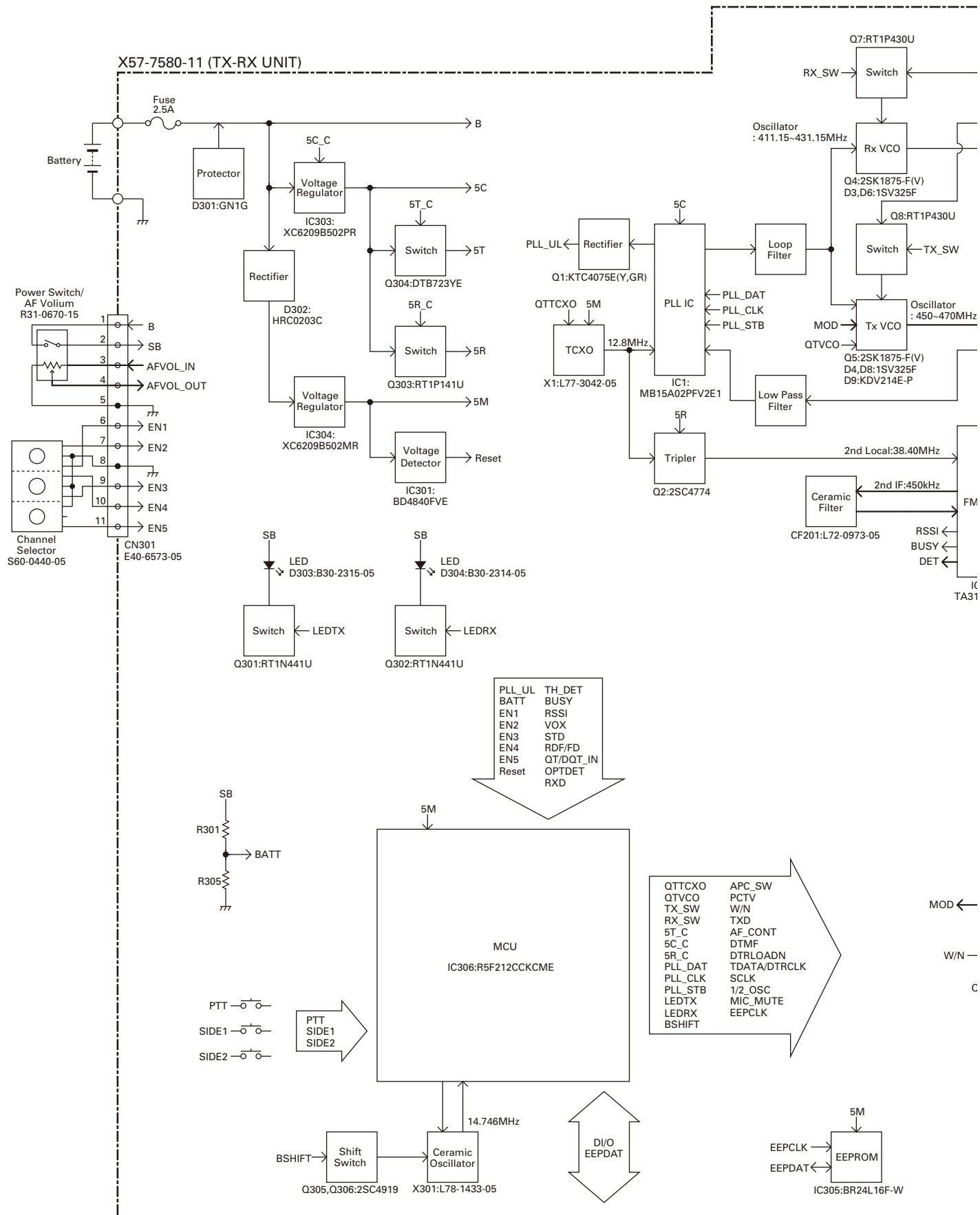

BLOCK DIAGRAM

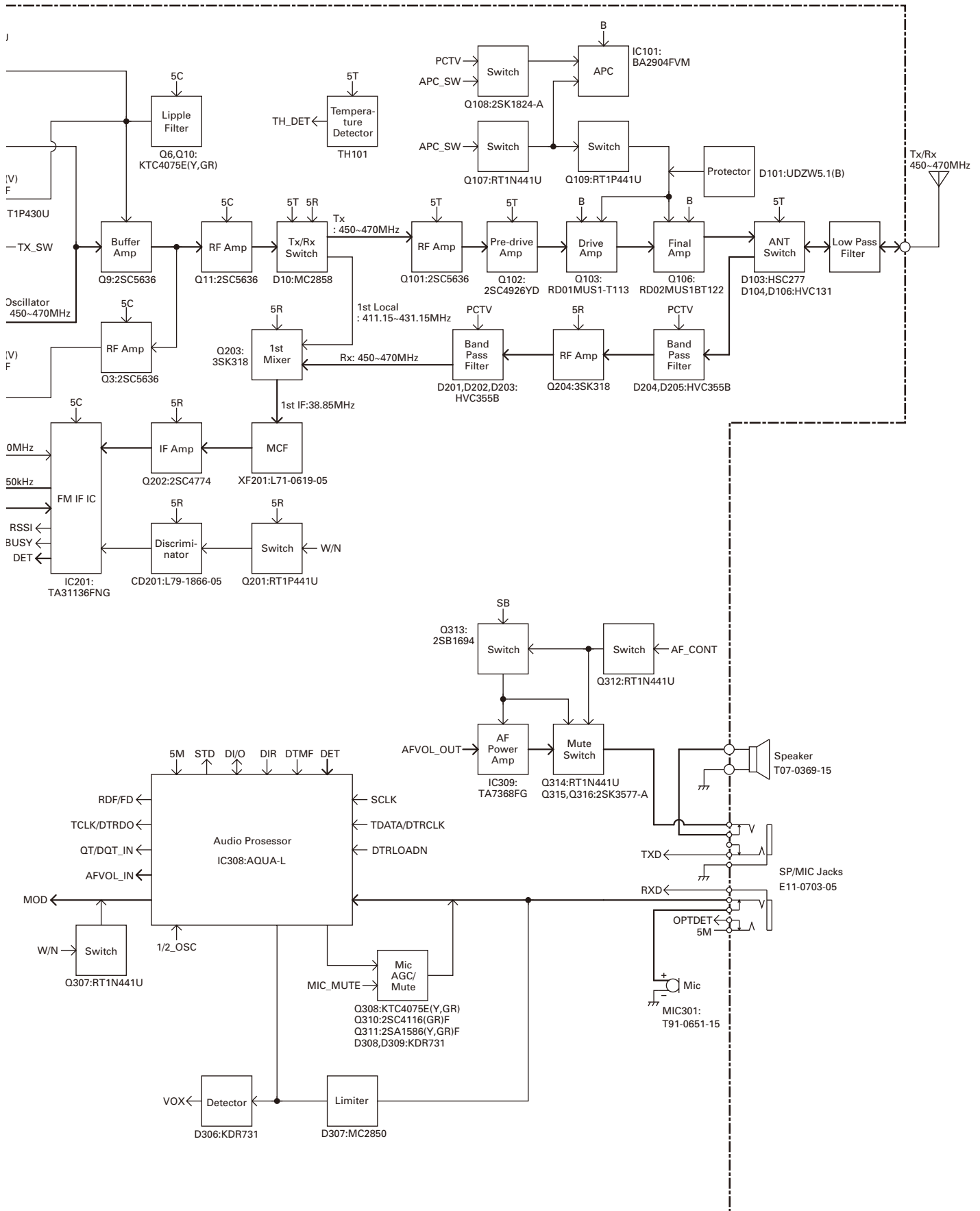

LEVEL DIAGRAM

Receiver Section

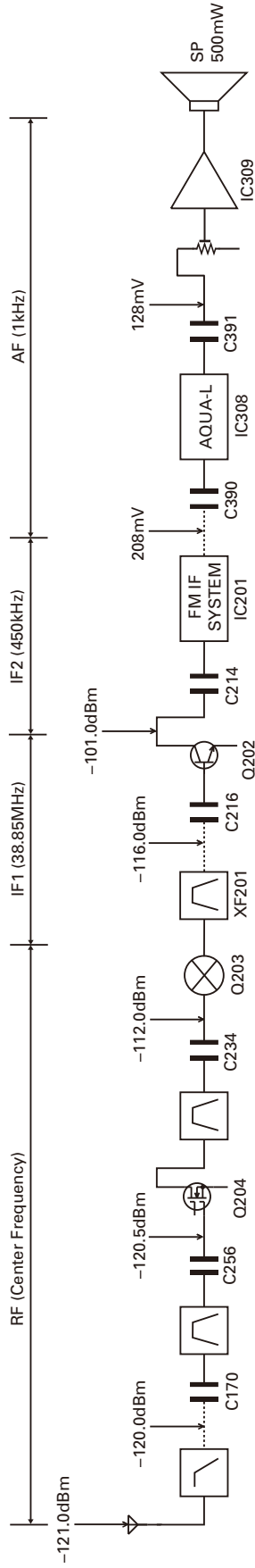

To make measurements in the AF section, connect the AC level meter. (ANT input: -53dBm, 1kHz FM, 3kHz DEV (WIDE).)
 In the RF section, use 470pF coupling capacitor. (The display shows the SSG input value required to obtain 12dB SINAD without Local Level.)

Transmitter Section

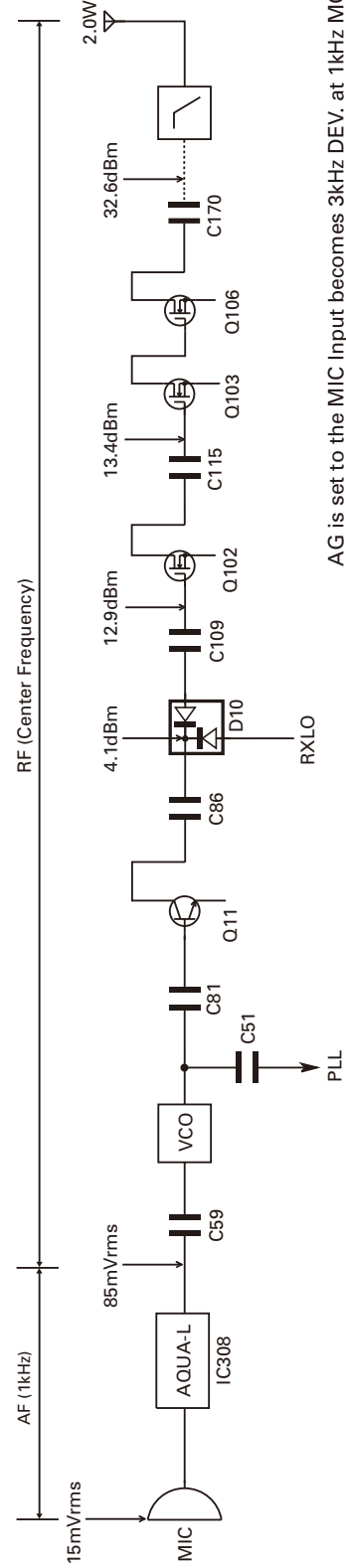

AG is set to the MIC Input becomes 3kHz DEV. at 1kHz MOD. (WIDE).
 To make measurements in the AF section, connect the AC level meter. In the RF section, use 470pF coupling capacitor.

SPECIFICATIONS

General

Frequency Range.....	450~470MHz
Number of channels	K: 4, K2: 16
Channel Spacing	25kHz (Wide) / 12.5kHz (Narrow)
PLL Channel Stepping	5kHz, 6.25kHz
Operating Voltage	7.5 V DC±20%
Battery Life	More than 18 hours at 2 watts (5-5-90 duty cycle with KNB-45L battery)
Operating Temperature range	-30°C to +60°C (-22°F to +140°F)
Frequency Stability	±2.5ppm (-30°C to +60°C)
Channel Frequency Spread.....	20MHz
Dimensions and Weight (Dimensions not including protrusions)	
Radio Only	160g (5.6oz)
With KNB-45L (2000mAh battery)	54 (2.13) W x 122 (4.8) H x 33.8 (1.33) D mm (inches)
	280g (9.9oz)

Receiver (Measurements made per TIA/EIA-603)

Sensitivity	
EIA 12dB SINAD.....	0.25µV (Wide) / 0.28µV (Narrow)
Selectivity	70dB (Wide) / 60dB (Narrow)
Intermodulation	65dB (Wide) / 60dB (Narrow)
Spurious response.....	60dB
Audio Power Output.....	500mW at 8Ω less than 10% distortion

Transmitter (Measurements made per TIA/EIA-603)

RF Power Output.....	2W/1W
Spurious and Harmonics.....	65dB
Modulation.....	16K0F3E (Wide) / 11K0F3E (Narrow)
FM Noise	45dB (Wide) / 40dB (Narrow)
Audio Distortion.....	Less than 5%

TK-3300

Kenwood Corporation

2967-3, Ishikawa-machi, Hachioji-shi, Tokyo, 192-8525 Japan

Kenwood U.S.A. Corporation

P.O. BOX 22745, 2201 East Dominguez Street, Long Beach,
CA 90801-5745, U.S.A.

Kenwood Electronics Canada Inc.

6070 Kestrel Road, Mississauga, Ontario, Canada L5T 1S8

Kenwood Electronics Deutschland GmbH

Rembrücker Str. 15, 63150 Heusenstamm, Germany

Kenwood Electronics Belgium N.V.

Leuvensesteenweg 248 J, 1800 Vilvoorde, Belgium

Kenwood Electronics France S.A.

L'Etoile Paris Nord 2, 50 Allée des Impressionnistes,
Bp 58416 Villepinte, 95944 Roissy Ch De Gaulle Cedex

Kenwood Electronics UK Limited

KENWOOD House, Dwight Road, Watford, Herts.,
WD18 9EB United Kingdom

Kenwood Electronics Europe B.V.

Amsterdamseweg 37, 1422 AC Uithoorn, The Netherlands

Kenwood Electronics Italia S.p.A.

Via G. Sirtori, 7/9 20129 Milano, Italy

Kenwood Ibérica, S.A.

Bolivia, 239-08020 Barcelona, Spain

Kenwood Electronics Australia Pty. Ltd.

(A.C.N. 001 499 074)

16 Giffnock Avenue, Centrecourt Estate, North Ryde, N.S.W. 2113 Australia

Kenwood Electronics (Hong Kong) Ltd.

Unit 3712-3724, Level 37, Tower one Metroplaza, 223 Hing Fong Road,
Kwai Fong, N.T., Hong Kong

Kenwood Electronics Singapore Pte Ltd

1 Ang Mo Kio Street 63, Singapore 569110



TK-3300 PC BOARD

PC BOARD TK-3300

**TX-RX UNIT (X57-7580-11)
Component side view (J79-0187-19)**

**TX-RX UNIT (X57-7580-11)
Component side view (J79-0187-19)**

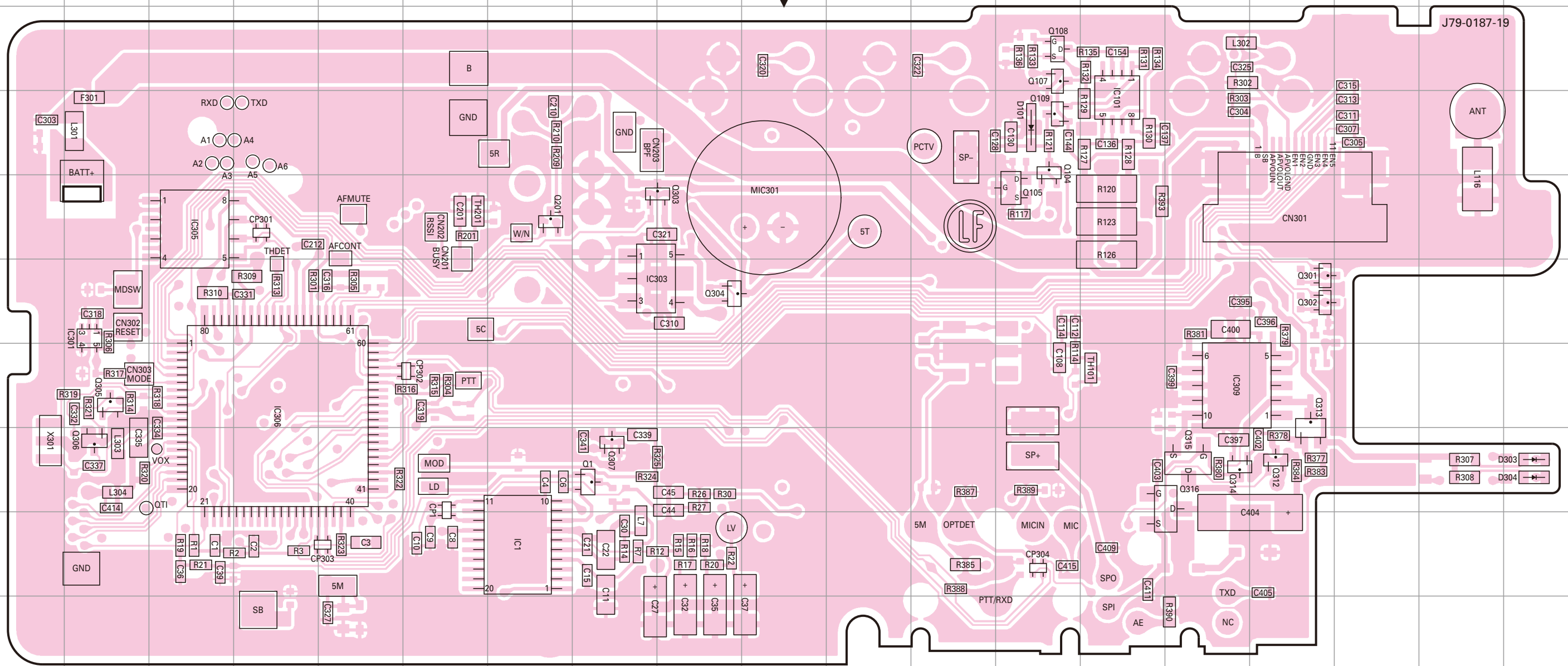

Ref. No.	Address	Ref. No.	Address	Ref. No.	Address	Ref. No.	Address
IC1	9G	Q104	4N	Q303	5I	Q315	8O
IC101	4N	Q105	5N	Q304	6I	Q316	8O
IC301	6B	Q107	3M	Q305	7B	D101	4M
IC303	6H	Q108	3M	Q306	8B	D303	8S
IC305	5C	Q109	4M	Q307	8H	D304	8S
IC306	7D	Q201	5G	Q312	8P		
IC309	7O	Q301	6P	Q313	7P		
Q1	8H	Q302	6P	Q314	8O		

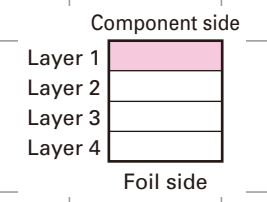

TK-3300 PC BOARD

PC BOARD TK-3300

TX-RX UNIT (X57-7580-11)
Foil side view (J79-0187-19)

TX-RX UNIT (X57-7580-11)
Foil side view (J79-0187-19)

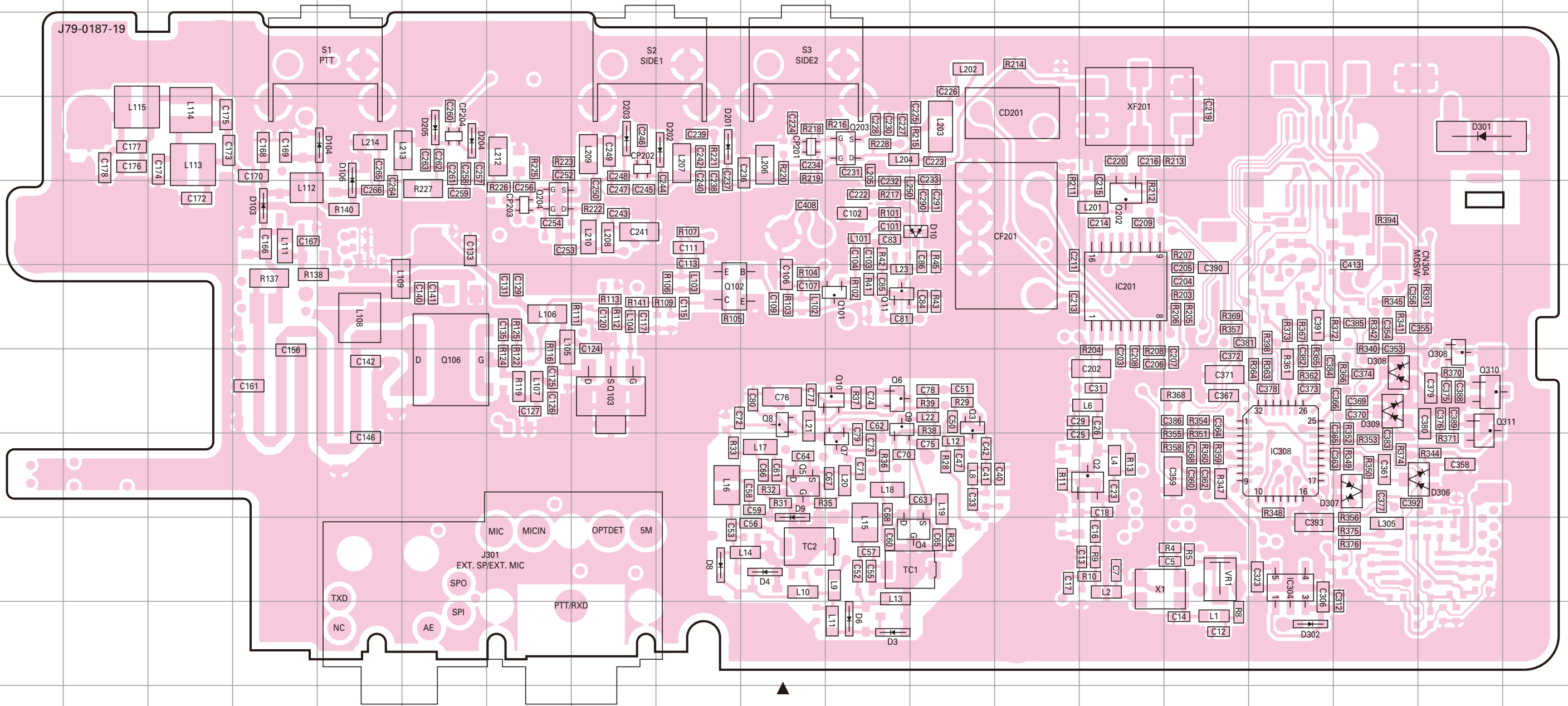

Ref. No.	Address	Ref. No.	Address	Ref. No.	Address	Ref. No.	Address	Ref. No.	Address
IC201	6N	Q8	7J	Q203	4K	D9	8J	D205	4F
IC304	9P	Q9	7K	Q204	5G	D10	5L	D301	4R
IC308	8P	Q10	7K	Q308	7R	D103	5D	D302	10P
Q2	8N	Q11	6K	Q310	7R	D104	4E	D306	8R
Q3	7L	Q101	6K	Q311	7R	D106	4E	D307	8Q
Q4	9L	Q102	6I	D3	10K	D201	4I	D308	7Q
Q5	8J	Q103	7H	D4	9J	D202	4I	D309	7Q
Q6	7K	Q106	7F	D6	10K	D203	4H		
Q7	8K	Q202	5N	D8	9I	D204	4F		

